

Shark[®] **Cordless Pro with CleanSense IQ**

IR300 Series

OWNER'S GUIDE



IMPORTANT SAFETY INSTRUCTIONS

FOR HOUSEHOLD USE ONLY



⚠ WARNING

When using an electrical appliance, to reduce the risk of fire, electric shock, injury, or property damage, basic precautions should always be followed, including the following:

READ ALL INSTRUCTIONS BEFORE USING THIS VACUUM:

1. This vacuum consists of a motorised nozzle, wand, and handheld vacuum. These components contain electrical connections, electrical wiring, and moving parts that potentially present risk to the user. The floor nozzle, wand, and handheld vacuum contain electrical connections.
2. Before each use, carefully inspect all parts for any damage. If a part is damaged, discontinue use.
3. Use only identical replacement parts.
4. This vacuum contains no serviceable parts.
5. Use only as described in this manual. **DO NOT** use the vacuum for any purpose other than those described in this manual.
6. With the exception of the filters and dust cup, **DO NOT** expose any parts of the vacuum to water or other liquids.
7. Keep the appliance and its cord out of reach of children. **DO NOT** allow the appliance to be used by children. **DO NOT** allow to be used as a toy. Close supervision is necessary when used near children.

GENERAL USE

8. This appliance can be used by persons with reduced physical, sensory, or mental capabilities or lack of experience and knowledge if they have been given supervision or instruction concerning use of the appliance in a safe way and understand the hazards involved. Cleaning and user maintenance shall not be made by children.
9. Always turn off the vacuum before connecting or disconnecting any current carrying hoses, motorised nozzles, chargers, batteries, or other electrical or mechanical parts.
10. **DO NOT** handle plug or vacuum with wet hands.
11. **DO NOT** use without dust cup, HEPA and Pre-motor filter, and soft roller in place.

12. Only use Shark® branded filters and accessories. Failure to do so will void the warranty.
13. **DO NOT** put any objects into nozzle or accessory openings. **DO NOT** use with any opening blocked; keep free of dust, lint, hair, and anything that may reduce airflow.
14. **DO NOT** use if nozzle or accessory airflow is restricted. If the air paths or the motorised floor nozzle become blocked, turn the vacuum off. Remove all obstructions before you turn on the unit again.
15. Keep nozzle and all vacuum openings away from hair, face, fingers, uncovered feet, or loose clothing.
16. **DO NOT** use if vacuum is not working as it should, or has been dropped, damaged, left outdoors, or dropped into water.
17. Use extra care when cleaning on stairs.
18. **DO NOT** leave the vacuum unattended while powered on.
19. When powered on, keep the vacuum moving over the carpet surface at all times to avoid damaging the carpet fibers.
20. **DO NOT** place vacuum on unstable surfaces such as chairs or tables.
21. **DO NOT** use to pick up:
 - a) Liquids
 - b) Large objects
 - c) Hard or sharp objects (glass, nails, screws, or coins)
 - d) Large quantities of dust (including drywall, fireplace ash, or embers). **DO NOT** use as an attachment to power tools for dust collection.
 - e) Smoking or burning objects (hot coals, cigarette butts, or matches)
 - f) Flammable or combustible materials (lighter fluid, gasoline, or kerosene)
 - g) Toxic materials (chlorine bleach, ammonia, or drain cleaner)

22. **DO NOT** use in the following areas:

- a) Poorly lit areas
- b) Wet or damp surfaces
- c) Outdoor areas
- d) Spaces that are enclosed and may contain explosive or toxic fumes or vapours (lighter fluid, gasoline, kerosene, paint, paint thinners, mothproofing substances, or flammable dust)

23. Turn off the vacuum before plugging in or unplugging the charger.

24. Turn off the vacuum before any adjustment, cleaning, maintenance or troubleshooting.

25. During cleaning or routine maintenance, **DO NOT** cut anything other than hair, fibers, or string wrapped around the brushrolls.

26. Allow all filters to air-dry completely before replacing in the vacuum to prevent liquid from being drawn into electric parts.

27. **DO NOT** modify or attempt to repair the vacuum or the battery yourself, except as indicated in this manual. **DO NOT** use the battery or vacuum if it has been modified or damaged. Damaged or modified batteries may exhibit unpredictable behavior resulting in fire, explosion, or risk of injury.

28. Always turn off this appliance before connecting or disconnecting motorised nozzle or hand tool.

BATTERY PACK

29. The battery is the power source for the vacuum. Carefully read and follow all charging instructions.

30. To prevent unintentional starting, ensure the vacuum is powered off before picking up or carrying the vacuum. **DO NOT** carry the appliance with your finger on the power switch.

31. Use only Shark® charger DK33-248080H-S or YLS0243A-A248080 for single battery packs. Use of an incorrect charger may result in no charging, and/or unsafe conditions. A charger that is suitable for one type of battery pack may create a risk of fire when used with another battery pack.

32. Keep the battery away from all metal objects such as paper clips, coins, keys, nails, or screws. Shorting the battery

terminals increases the risk of fire or burns

33. Under abusive conditions, liquid may be ejected from the battery. Avoid contact with this liquid, as it may cause irritation or burns. If contact occurs, flush with water. If liquid contacts eyes, seek medical help.

34. Battery should not be stored at temperatures below 3°C (37.4°F) or above 104°F (40°C) to maintain long-term battery life.

35. **DO NOT** charge battery at temperatures below 5°C (40°F) or above 104°C (104°F). Charging improperly or at temperatures outside of the specified range may damage the battery and increase the risk of fire.

36. Store the appliance indoors. **DO NOT** use or store it below 3°C (37.4°F). Ensure the appliance is at room temperature before operating.

37. **DO NOT** expose the battery to fire or temperatures above 265°F (130°C) as it may cause explosion.

38. Use appliances only with specifically designated battery packs. Use of any other battery packs may create a risk of injury and fire.

39. Disconnect the battery pack from the appliance before making any adjustments, changing accessories, or storing appliance. Such preventive safety measures reduce the risk of starting the appliance accidentally.

40. For IR300ANZ use only with Shark battery pack XBATR625SL.

41. To reduce the risk of shock and unintended operation, turn off power and remove the Li-Ion battery before servicing.

SAVE THESE INSTRUCTIONS

ASSEMBLY

1. Insert **Wand** into **Floor Nozzle**.
2. Insert **Handheld Vacuum** into wand.

For proper operation, ensure all components are completely connected and clicked into place.

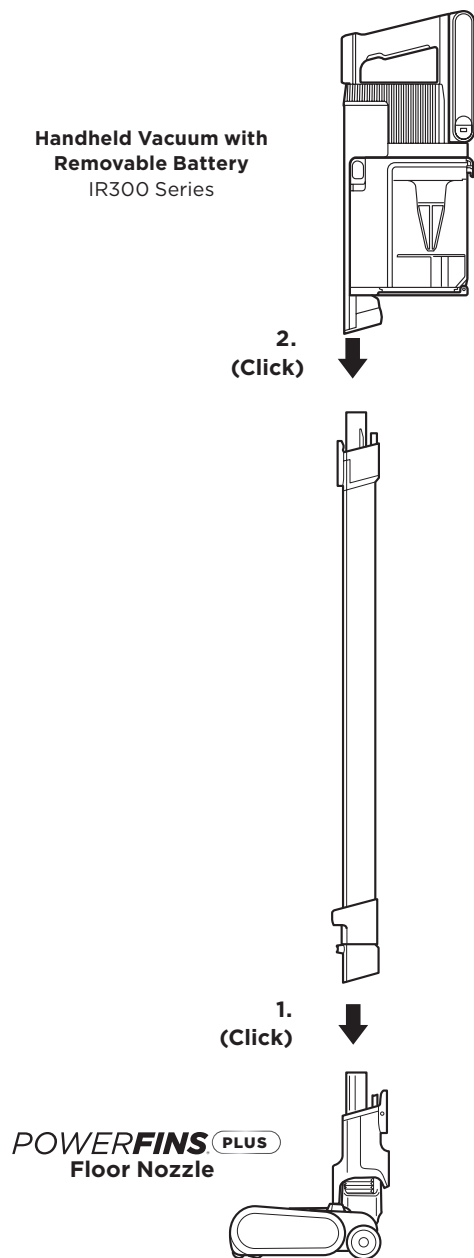

LI-ION BATTERY

The **Lithium-Ion Power Pack battery does not come fully charged**. Prior to first use, charge completely. During first use, run the battery down until it is completely out of power. This will condition the battery.

LED BATTERY POWER AND CHARGING INDICATORS

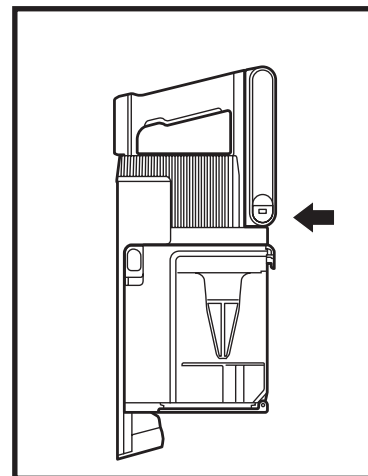

Charging

- LED will pulse white when reaching 100% charge.
- LED will pulse green from 76% - 99% charge.
- LED will pulse yellow from 0 - 75% charge.
- No LED the battery pack is off

NOTE: Full charge takes approximately 3.5 hours.

Additional Notes

1. LEDs turn off once the battery is fully charged.
2. Unit will not power on when charger is connected.

ABOUT YOUR ION POWER PACK BATTERY

This product uses a lithium-ion rechargeable and recyclable battery. When the battery no longer holds a charge, it should be removed from the vacuum and recycled. **DO NOT** incinerate or compost the battery. When your Lithium-Ion Power Pack Battery needs to be replaced, dispose of it or recycle it in accordance with local regulations. In some areas, it is illegal to place spent lithium-ion batteries in the rubbish or municipal solid waste stream. Return spent power packs to an authorised recycling center or to retailer for recycling. Contact your local recycling center for information on where to drop off the spent power pack.

SUCTION POWER MODES

SUCTION MODE DISPLAY LIGHTS

- ECO Mode**
Maximum runtime. Saves battery power.
- Clean Sense IQ Mode**
Best balance between suction power and optimised runtime. Best used on carpet AND hard floor.
- Boost Mode**
Maximum suction. Uses the most battery power.

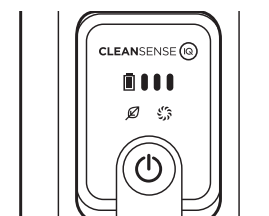

Battery Runtime

MODE	MINUTES
	IR300
Hand Vac - ECO Mode	50
Boost Mode (Hand Vac)	10

Suction mode impacts runtime. Use Boost in short bursts.

CHARGING THE BATTERY

USING THE LI-ION CHARGER

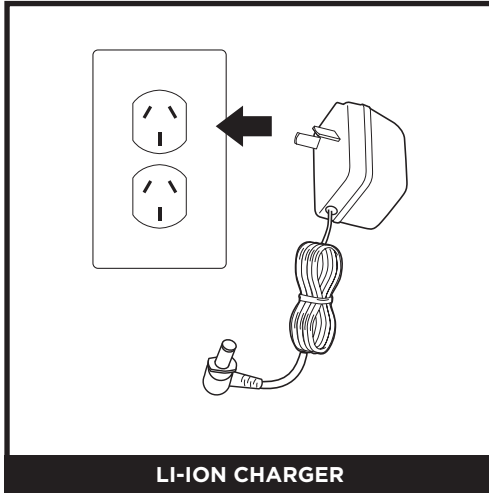

Plug the **Li-Ion Charger** into a wall outlet.

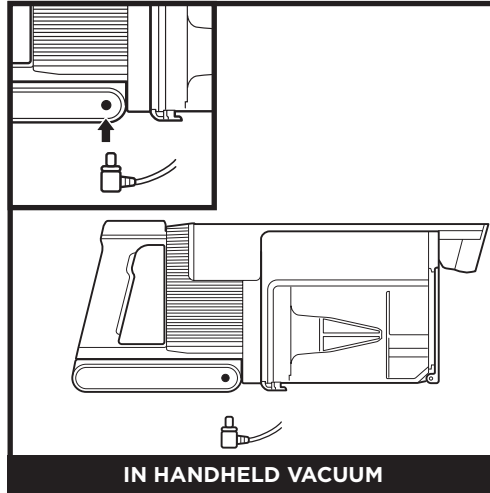

To charge the battery inside the handheld vacuum, connect the charger to an electrical outlet, then insert the charger plug into the port below the handle on the handheld vacuum.

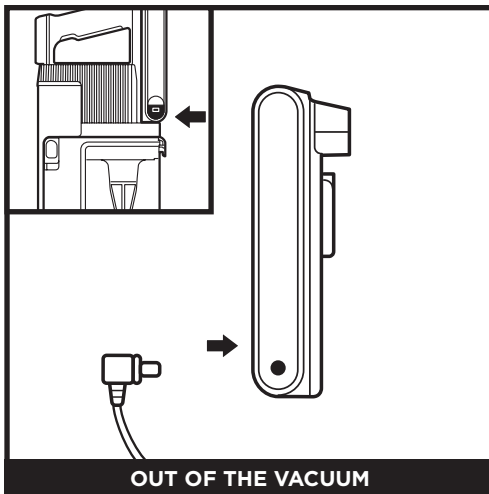

Press and hold the **Battery Release Button**, then slide out the battery. Plug the charger into the charging port on the battery. To reinstall the battery, slide it into the slot in the back of the handheld vacuum.

SETTINGS

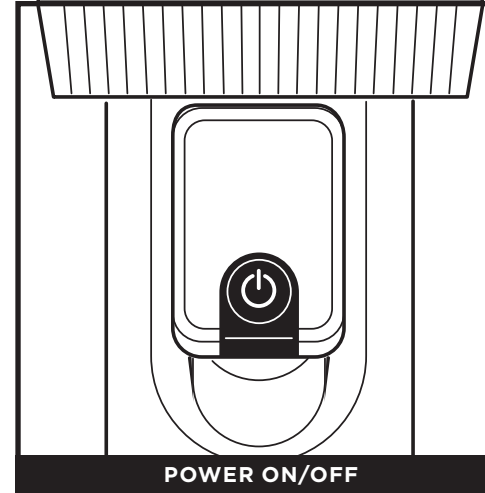

Press power button to turn vacuum on or off.

NOTE: The unit will not turn on if the charger is connected. Unplug the charger before turning on vacuum power.

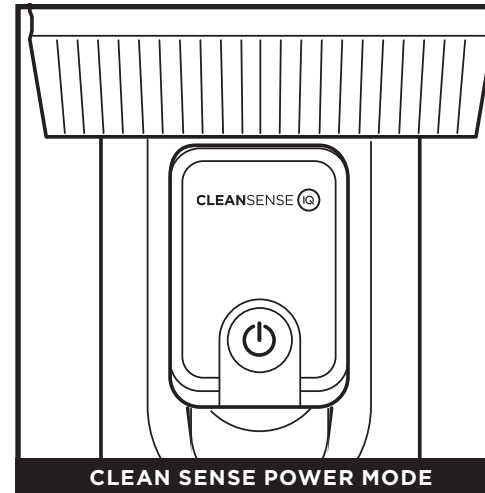

Clean Sense IQ senses the dirt you can't see and automatically boosts power. Clean Sense IQ mode modifies cleaning performance based on the mess at hand, giving you optimal suction and runtime when heavy or light debris is detected.

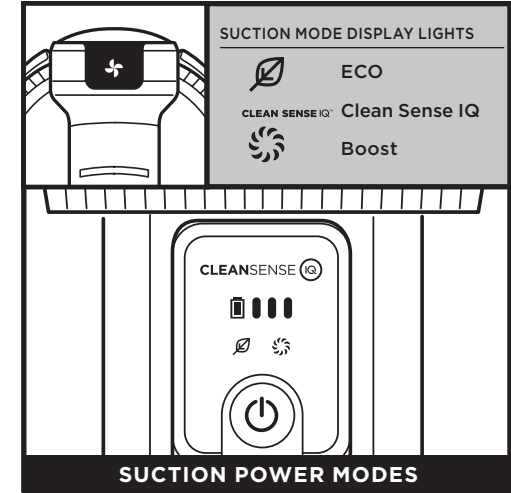

Press the button to toggle between ECO, Clean Sense IQ, and Boost modes. To save battery power, select ECO mode. For everyday cleaning power, select Clean Sense IQ mode. For an extra burst of power, select Boost mode.

CLEANING MODES

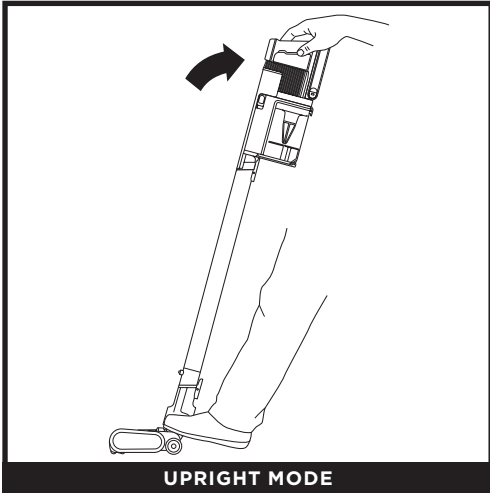

To clean floors, step on floor nozzle and tilt handheld vacuum back.

NOTE: Brushrolls will only engage when the handheld vacuum is tilted back and the nozzle swivel is unlocked.

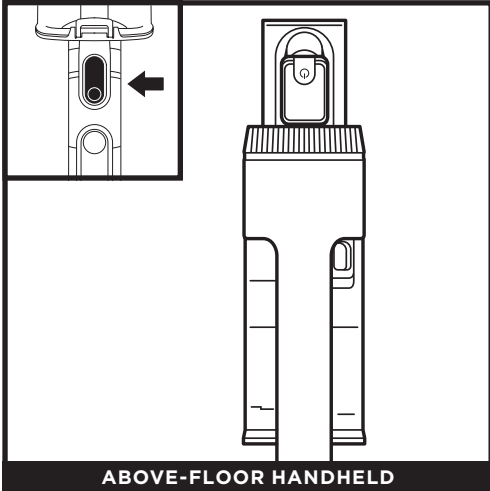

Press the wand release button and lift the handheld vacuum off the wand. Attach an accessory for cleaning on stairs, furniture, and other above-floor areas.

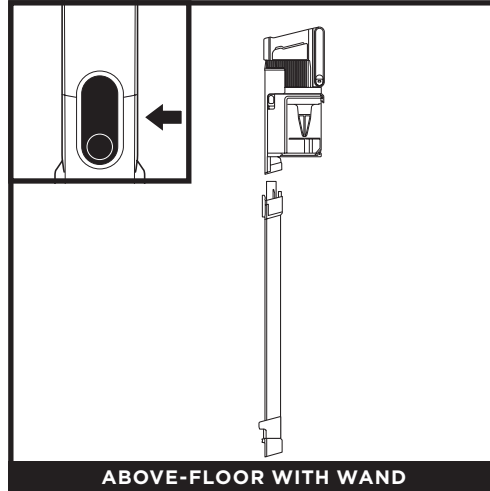

Stand the vacuum upright and press the nozzle release button located at the bottom of the wand, above the nozzle. Lift wand to detach. Great for cleaning baseboards, ceiling fans, window sills, and other hard-to-access areas.

NOTE: All accessories are compatible with both the wand and the handheld vacuum.

ONBOARD STORAGE

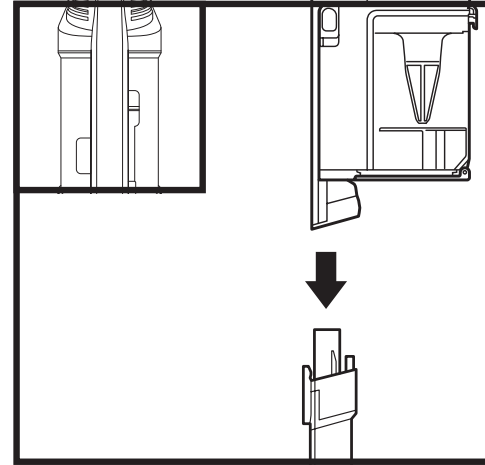

Press the Wand Release button at the top of the wand to detach the handheld vacuum.

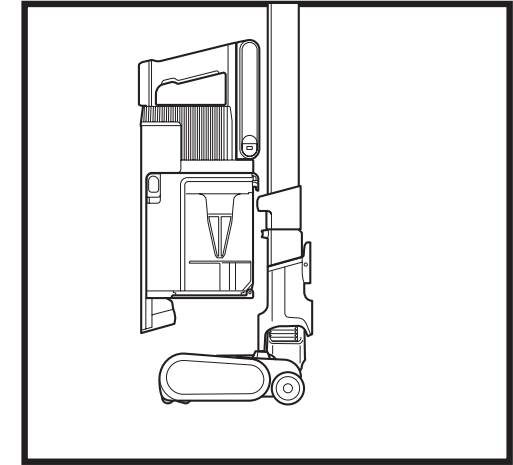

Hang the handheld vacuum from the storage hook on the wand.

MAINTAINING YOUR VACUUM

EMPTYING THE DUST CUP

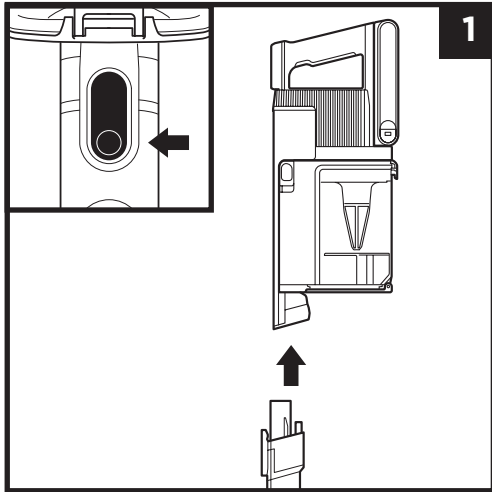

Press the wand release button to detach the handheld vacuum from the wand.

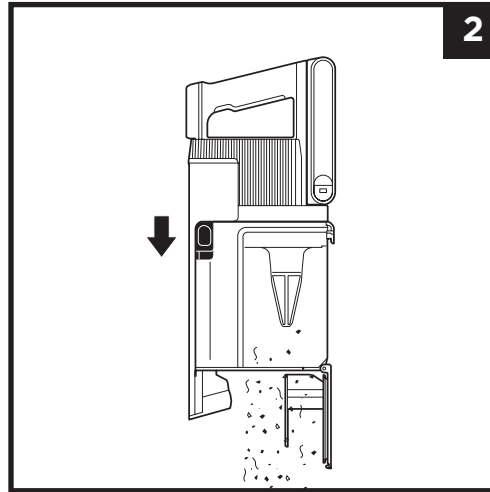

To empty the **Dust Cup** while it is attached to the handheld vacuum, position the dust cup over a trash receptacle and slide the **CleanTouch® Dirt Ejector** slider forward.

REMOVING AND CLEANING THE DUST CUP

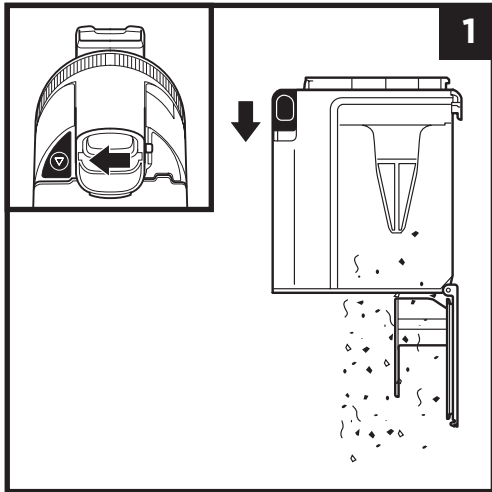

To remove the dust cup from the handheld vacuum, press the **CleanTouch Dust Cup Release** button near the handheld vacuum nozzle. Tilt the dust cup and lift off to remove. To empty dust and debris, hold the dust cup over the trash receptacle, then slide the CleanTouch Dirt Ejector slider forward.

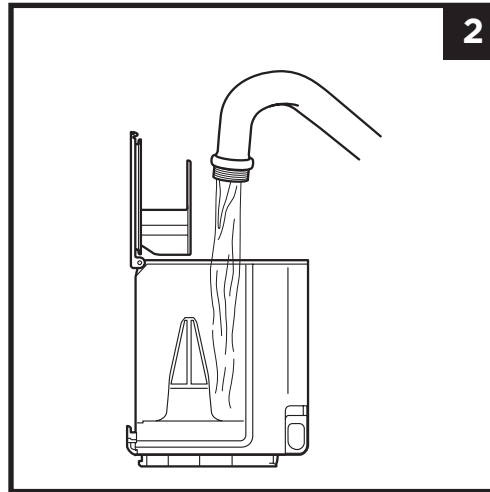

To clean the interior of the dust cup, rinse it with water. Place it on its side with the lid open to air-dry for at least 48 hours before reinstalling.

MAINTAINING YOUR VACUUM

CLEANING THE FILTERS

Regularly rinse and replace the filters to maintain your vacuum's suction power.

To clean filters, rinse them with water only. **Allow all filters to air-dry completely up to 48 hours before reinstalling to prevent liquid from being drawn into electric parts.** Clean the pre-motor filters at least once a month and post-motor HEPA filter at least once a year. Tap off loose dirt between washes when needed. More frequent cleaning may sometimes be necessary with heavy use.

IMPORTANT: DO NOT use soap when cleaning the filters. Use water only. The vacuum will not have suction if the post-motor HEPA filter is not installed. Ensure that all filters are installed before using.

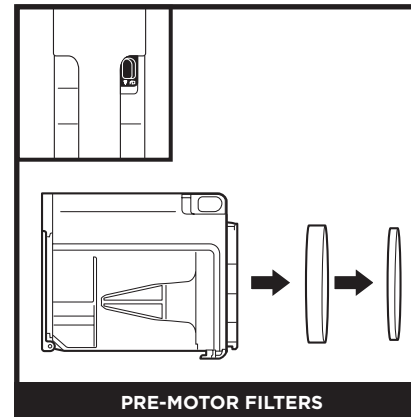

Remove the dust cup, and pull the foam and felt filters out of the back of the dust cup.

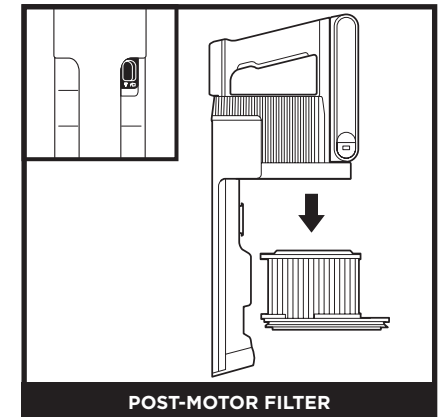
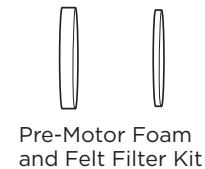

Remove the dust cup. Pull the post-motor filter out of the handheld vacuum.



MAINTAINING YOUR VACUUM

FLOOR NOZZLE

If any hair is wrapped around the brushrolls, continue cleaning using the Carpet setting on a bare floor surface, a low-pile carpet, or a small area rug. If some fibers remain wrapped around the brushrolls after continued use, carefully remove them. If you run over a hard or sharp object or notice a change in noise while vacuuming, check the floor nozzle for blockages. (See the Checking for Blockages in the Floor Nozzle section.)

CLEANING SOFT ROLLER

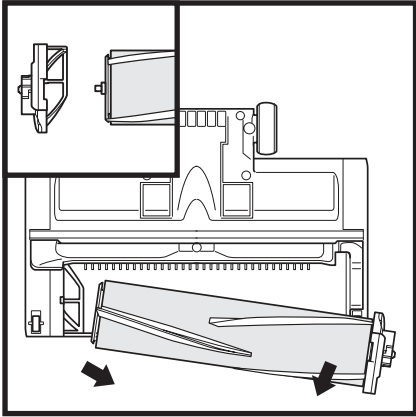

1. To remove the Soft Roller from the nozzle, turn off the vacuum and detach the wand. Use the edge of a coin to open the lock on the bottom of the floor nozzle. Pull the Soft Roller out by the tab.
2. Tap loose debris off the Soft Roller. Use a dry towel to wipe the Soft Roller clean and to remove any debris caught in the teeth behind the Soft Roller.
3. Hand wash the Soft Roller as needed. Use only water, and let air-dry completely, which should take at least 24-48 hours.
4. Reinsert Soft Roller until you feel it click into place.

CLEANING THE SENSORS

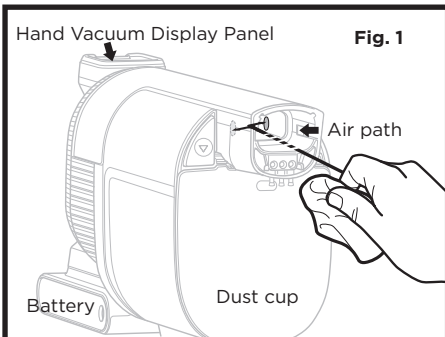

Hand Vacuum Display Panel

Fig. 1



Make sure to clean the sensors inside the hand vacuum regularly, as hair and other debris may build up and obstruct them (Fig. 1). If the sensors are partially obstructed, Clean Sense IQ mode will not adjust suction levels as expected. If the sensors are completely obstructed, the FO error code will appear and the Clean Sense IQ icon will flash on the hand vacuum display panel.

To clean the sensors:

1. Turn off power and remove the hand vacuum.
2. Locate the sensors inside the nozzle of the hand vacuum. The sensors are on the interior walls of the nozzle, about 8 cm down the air path, aligned with the IQ logos (Fig.2) on the exterior.
3. Gently wipe the sensors with a microfibre cloth and remove all hair and debris.
4. Turn on power and verify that the unit is functioning normally.

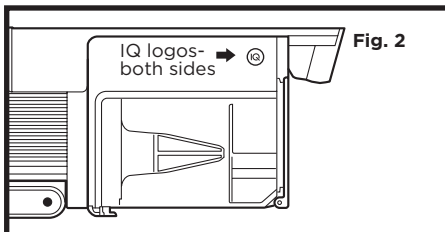

Fig. 2

CLEAN SENSE IQ SENSORS

IQ logos-
both sides

MAINTAINING YOUR VACUUM

CHECKING FOR BLOCKAGES

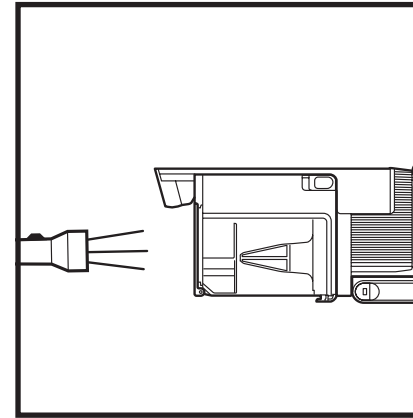

Checking for Blockages in the Handheld Vacuum:

1. Turn off vacuum.
2. Remove the handheld vacuum from the wand.
3. Check all intake openings on the dust cup and remove any debris or blockage.

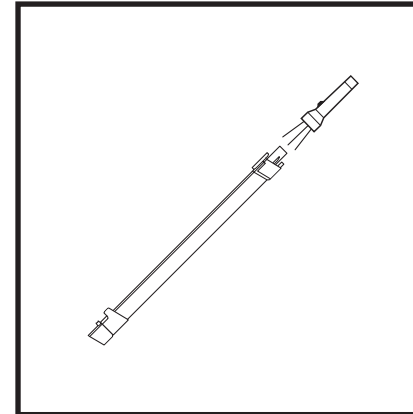

Checking for Blockages in the Wand:

1. Turn off vacuum.
2. Remove the handheld vacuum and floor nozzle.
3. Look through wand to check for any blockages.
4. Clear away debris and blockages.

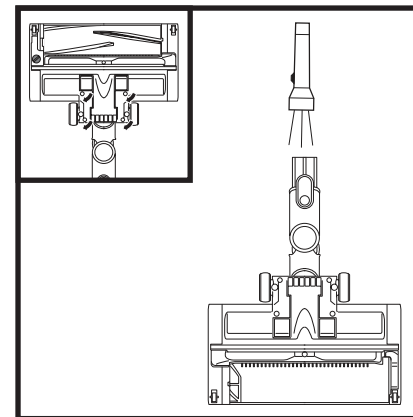

Checking for Blockages in the Floor Nozzle:

1. Turn off vacuum.
2. Detach the wand.
3. Use the edge of a coin to open the three locks on the bottom of the floor nozzle.
4. Remove the cover and tilt back the neck of the floor nozzle.
5. Check the opening and remove any debris.
6. Replace the cover by sliding the inserts into the slots, then pressing down firmly on all sides. Turn the locks clockwise to close, until they click securely into place.

TROUBLESHOOTING GUIDE

⚠ WARNING: To reduce the risk of shock and unintended operation, turn off power and remove the Lithium-Ion Power Pack battery before servicing.

Vacuum is not picking up debris. No suction or light suction. Filter icon on handheld vacuum control panel is red. (Refer to Checking for Blockages section for more information.)

- Check filters to see if they need cleaning. Follow instructions for rinsing and completely air-drying the filters before reinserting in the vacuum.
- Dust cup may be full; empty dust cup.
- Check floor nozzle for blockages; clear blockages if required.
- Remove any string, carpet fibers, or hair that may be wrapped around the brushrolls.
- Check clog access hose in wand for any blockages and clear any debris.
- Check connectors between handheld, wand, and floor nozzle for debris. Remove any dust or material in the connectors.
- If the issue persists, please contact Customer Service at **AUS +61 2 8801 7666 NZ +64 800 112 660**.

Vacuum lifts area rugs.

- Make sure you are not engaging Boost mode as this can be too much suction for lighter rugs. Take care when vacuuming area rugs or rugs with delicately sewn edges.
- Turn off the unit to disengage the brushrolls and press the power button to restart.

Brushrolls do not spin.

- Immediately turn off the vacuum. Remove any blockages before turning the vacuum back on. Make sure the handheld vacuum is tilted back far enough for the brushrolls to engage. If the brushrolls still do not spin, please contact Customer Service at **AUS +61 2 8801 7666 NZ +64 800 112 660**.
- If the floor nozzle has headlights and they are not illuminated, there is a connection issue between the handheld vacuum, wand, and nozzle. Try disconnecting and reattaching the pieces. If the headlights still do not illuminate, please contact Customer Service at **AUS +61 2 8801 7666 NZ +64 800 112 660**.

Vacuum turns off on its own.

There are several possible reasons for the vacuum turning off on its own, including blockages, battery issues, and overheating. If vacuum turns off on its own, perform the following steps:

1. Turn on the vacuum and check the battery indicator lights located on the handheld vacuum. If recharging is needed, make sure power is turned off before connecting to the charger.
2. Empty dust cup and clean filters (see Emptying the Dust Cup and Cleaning the Filters sections).
3. Check wand, accessories, and inlet openings and remove any blockages.
4. Allow unit and battery to cool for at least 45 minutes, until they return to room temperature.
5. Press power button to restart the vacuum. Make sure the charger is not plugged into the port on the handheld vacuum.









Vacuum is emitting air that smells bad.

- Dust cup may be full; empty dust cup. Empty dust cup after each use for optimal odor neutraliser technology performance.
- Check filters to see if they need cleaning. Follow instructions for rinsing and air-drying the filters before reinstalling them.
- Check to make sure odor cartridge is installed in the dial and the dial is installed in the nozzle.
- Check the odor neutraliser technology dial on the nozzle to see what setting is enabled.
- If odor neutraliser technology dial is at any setting from Low to High and the cartridge has been installed for 6 months or longer, consider replacing it.
- If the odor cartridge is still emitting a scent but you dislike it, consider turning the intensity down, or reinstall the dial in the nozzle without the cartridge.
- If the odor neutraliser technology cartridge is not emitting a scent, consider replacing it.

For all other issues, please call Customer Service **AUS +61 2 8801 7666 NZ +64 800 112 660**.

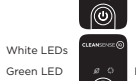
NOTE: If vacuum still does not operate properly, contact Customer Service **AUS +61 2 8801 7666 NZ +64 800 112 660**. For more troubleshooting help and FAQs, visit sharkclean.com/support.

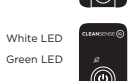
TROUBLESHOOTING GUIDE

	Fault	Error code display on	
Motor	Motor No Start	All white LEDs, 1 green, and 1 red are flashing on hand vacuum display.	
	Motor Overheat	All white LEDs and 1 green are flashing on hand vacuum display.	
	Motor Overcurrent	All white LEDs and 1 red are flashing on hand vacuum display.	
	Motor Short	All white LEDs are flashing on hand vacuum display.	
	Motor Overspeed	State of charge and red boost icon are flashing on hand vacuum display.	
	System Comm Error	Clean Sense IQ, ECO, and Boost Icons are all flashing on hand vacuum display.	
	Clean Sense IQ Sensor Blockage	The FO code and Clean Sense IQ Icon are flashing on the hand vacuum display.	
Nozzle	Nozzle Overheat	Clean Sense IQ and ECO Icons are flashing on hand vacuum display.	
	Nozzle Short	Clean Sense IQ and Boost icons are flashing on hand vacuum display.	

ADDITIONAL ACCESSORIES AVAILABLE ON AU SHARKCLEAN.COM.AU | NZ SHARKCLEAN.CO.NZ

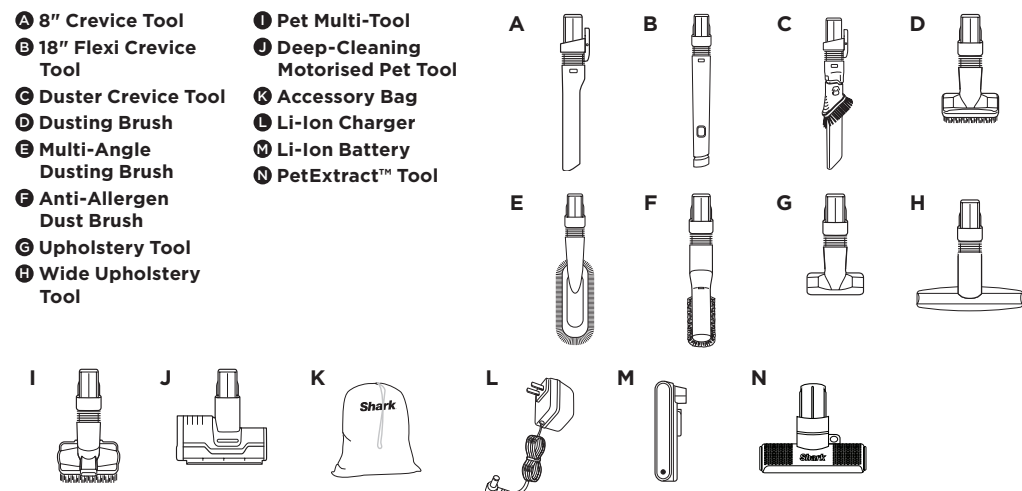

NOTE: Not all accessories come with all units. For a list of the accessories included with this model, see the top inside flap of the box. To order additional accessories, visit **AU sharkclean.com.au | NZ sharkclean.co.nz**.

TWO (2) YEAR LIMITED REPLACEMENT WARRANTY

The warranty commences on the date of purchase and expires at the end of the two-year period. In the unlikely event of a defect due to faulty materials or workmanship within the guarantee period we will replace the defective/faulty part with a new product, free of charge, or if the unit is deemed defective/faulty we replace the unit with an equivalent or upgraded model, at our discretion.

For warranty claims, you will need to submit a proof of purchase in the form of a valid receipt that displays date and place of purchase.

Your warranty is subject to the following conditions

- DO NOT operate the appliance with a damaged plug or cord, or if the unit has been dropped, damaged or dropped in water.
- To avoid the risk of electric shock, do not disassemble or attempt to repair the appliance on your own. If the supply cord is damaged, it must be replaced by a qualified electrician to avoid a hazard. Incorrect re-assembly or repair can cause a risk of electric shock or injury to persons when the appliance is used.
- The item has not been misused, abused, neglected, altered, modified or repaired by anyone.
- The item has been subjected to fair wear and tear.
- The item has not been used for trade, professional or hire purposes.
- The item has not sustained damage through foreign objects, substances or accident

Customer costs within warranty

The customer is responsible for any inwards freight charge to return a product for warranty if requested, and outward freight charge for warranty parts and or replacement unit.

Who is covered?

This warranty applies only to the original purchaser, who bought the product from an authorised retailer and may not be transferred. Proof of purchase is required.

What is not covered?

- Filters and brush rolls
- Accessories supplied with the item.
- Components that are subject to natural wear and tear caused by normal use in accordance with operating instructions.
- Unauthorised/improper maintenance/handling or overload is excluded from this warranty.
- Accidental damage
- Damage as a result of use not in accordance with the rating plate
- Removal of blockages. If a blockage does occur please refer to the trouble shooting guide within your Shark Operating manual
- Use of parts and accessories that are not genuine Shark components

REGISTER YOUR PURCHASE

 AU sharkclean.com.au
NZ sharkclean.co.nz

 Scan QR code using
mobile device



RECORD THIS INFORMATION

Model Number: _____

Serial Number: _____

Date of Purchase: _____
(Keep receipt)

Store of Purchase: _____

TECHNICAL SPECIFICATIONS

Voltage: 21.6V-, 60Hz

Watts: 181W

PLEASE READ CAREFULLY AND KEEP FOR FUTURE REFERENCE.

This Owner’s Guide is designed to help you get a complete understanding of your new Shark® Cordless Pro with CleanSense IQ.

Mann&Noble Pty Ltd
Building D, 33 Quarry Road
Erskine Park NSW, Australia, 2759
AU 02 8801 7666 | **NZ** 0800 112 660
AU sharkclean.com.au | **NZ** sharkclean.co.nz

Illustrations may differ from actual product. We are constantly striving to improve our products; therefore the specifications contained herein are subject to change without notice.

This product may be covered by one or more U.S. patents. See sharkninja.com/patents for more information.

© 2023 SharkNinja Operating LLC. CLEAN TOUCH , MULTIFLEX, POWERFINS and SHARK are registered trademarks of SharkNinja Operating LLC. PETEXTRACT is a trademark of SharkNinja Operating LLC.

 [@sharkcleanau](#) | [@sharkcleannz](#)

 [@sharkcleanau](#) | [@sharkcleannz](#)

 [@sharkcleananz3015](#)