

Shark[®]

ROTATOR[™]

NV600ANZMN

Series

INSTRUCTIONS



 sharkclean.com.au

 AUS 1800 099 385
NZ 0800 11 660

THANK YOU

for purchasing the Shark® Rotator Lift-Away Speed™

REGISTER YOUR PURCHASE

 sharkclean.com.au

 AUS 1800 099 385
NZ 0800 11 660

RECORD THIS INFORMATION

Model Number: _____

Date Code: _____

Date of Purchase (Keep receipt): _____

Store of Purchase: _____

TECHNICAL SPECIFICATIONS

Voltage: 120V., 60Hz

Watts: 900W

Amps: 7.5A

PLEASE READ CAREFULLY AND KEEP FOR FUTURE REFERENCE.

This Owner's Guide is designed to help you get a complete understanding of your new Shark Rotator Lift-Away Speed.

If you have any questions, please call the customer service line at AUS 1800 099 385
NZ 0800 112 660

CONTENTS

Important Safety Instructions	3
Getting to Know Your Shark® Rotator Lift-Away Speed™	5
Assembling Your Vacuum	7
Using Your Vacuum in Upright Mode	9
What Does the Brushroll Indicator Light Mean?	9
Using Your Vacuum in Above-Floor Mode	11
The Benefits of Suction Control	11
Using Your Vacuum in Lift-Away Mode	13
Lift-Away Cleaning	13
Compatible Accessories	15
Maintenance	17
Emptying the Dust Cup	17
Cleaning the Filters	18
Checking for Blockages & Maintaining Brushroll	19
Troubleshooting Guide	21
Warranty	22

IMPORTANT SAFETY INSTRUCTIONS

PLEASE READ CAREFULLY BEFORE USE • FOR HOUSEHOLD USE ONLY

⚠ WARNING

To reduce the risk of injury, fire, electric shock, and property damage resulting from improper use of the appliance, carefully observe the following instructions. This unit contains electrical connections and moving parts that potentially present risk to the user.

THE POWER NOZZLE, WAND, AND HANDLE CONTAIN ELECTRICAL CONNECTIONS:

- These are not serviceable parts.
- Do not use to vacuum any liquids.
- Do not immerse in water.
- If handle/wand is damaged, discontinue use.

- 1 Inspect power cord and plug for any damage before use. DO NOT use vacuum cleaner with a damaged cord or plug. Turn off all controls before plugging in or unplugging the vacuum cleaner. Store your vacuum cleaner with the power cord secured around the two cord hooks.
- 2 DO NOT use outdoors or on wet surfaces. Use only on dry surfaces.
- 3 Unplug from electrical outlet when not in use and before servicing.
- 4 If vacuum cleaner is not working as it should, or has been dropped, damaged, left outdoors, or dropped into water, return it to SharkNinja Operating LLC for examination, repair, or adjustment.
- 5 The hose contains electrical wires. DO NOT use when damaged, cut, or punctured.
- 6 DO NOT pull or carry vacuum cleaner by the cord or use the cord as a handle.
- 7 DO NOT unplug by pulling on cord. Grasp the plug, not the cord.
- 8 DO NOT handle plug or vacuum cleaner with wet hands.

- 9 DO NOT run the vacuum cleaner over the power cord, close a door on the cord, or pull the cord around sharp corners.
- 10 The use of an extension cord is NOT recommended.
- 11 DO NOT leave vacuum cleaner unattended when plugged in.
- 12 Keep cord away from heated surfaces.
- 13 Always turn off the vacuum cleaner before connecting or disconnecting motorized nozzle.

GENERAL USE

- 14 Use only as described in this manual.
- 15 Keep your work area well lit.
- 16 Keep the vacuum cleaner moving over the carpet surface at all times to avoid damaging the carpet fibers.
- 17 DO NOT place vacuum cleaner on unstable surfaces such as chairs or tables.
- 18 DO NOT put any objects into openings. DO NOT use with any opening blocked; keep free of dust, lint, hair, and anything that may reduce airflow.
- 19 DO NOT allow the appliance to be used by children. Close supervision is necessary when used near children. This is not a toy.
- 20 DO NOT use without dust cup and/or filters in place.

DUST CUP/FILTERS/ACCESSORIES

Before turning on the vacuum:

- 21 Make sure that all filters are thoroughly dry after routine cleaning.
- 22 Make sure that dust cup and all filters are in place after routine maintenance.
- 23 Make sure accessories are free of blockages.
- 24 Only use Shark®-brand filters and accessories (failure to do so will void the warranty).

HOSE ATTACHMENTS

- 25 DO NOT use if airflow is restricted. If the air paths or the motorized floor nozzle become blocked, turn the vacuum cleaner off and unplug from electrical outlet. Remove all obstructions before you turn on the unit again.
- 26 Keep the end of the hose and accessory openings away from face and body.
- 27 Keep cleaning tools and hose suction openings away from hair, face, fingers, uncovered feet, or loose clothing.
- 28 Only use manufacturer's recommended attachments.

GENERAL CLEANING

- 29 DO NOT vacuum up large objects.
- 30 DO NOT vacuum up hard or sharp objects such as glass, nails, screws, or coins that could damage the vacuum cleaner.

- 31 DO NOT vacuum up drywall dust, fireplace ash, or embers. DO NOT use as an attachment to power tools for dust collection.
- 32 DO NOT vacuum up smoking or burning objects such as hot coals, cigarette butts, or matches.
- 33 DO NOT vacuum up flammable or combustible materials (e.g., lighter fluid, gasoline, or kerosene) or use vacuum in areas where they may be present.
- 34 DO NOT vacuum up toxic solutions (e.g., chlorine bleach, ammonia, or drain cleaner).
- 35 DO NOT use in an enclosed space where vapors are present from paint, paint thinner, moth-proofing substances, flammable dust, or other explosive or toxic materials.
- 36 DO NOT vacuum up any liquids.
- 37 DO NOT immerse vacuum cleaner in water or other liquids.
- 38 Use extra care when cleaning on stairs.

POLARIZED PLUG

To reduce the risk of electric shock, this vacuum cleaner has a polarized plug (one blade is wider than the other). As a safety feature, this plug will fit into a polarized outlet only one way. If the plug does not fit fully into the outlet, reverse the plug. If it still does not fit, contact a qualified electrician. DO NOT force into outlet or try to modify to fit.

SAVE THESE INSTRUCTIONS

GETTING TO KNOW YOUR SHARK® ROTATOR LIFT-AWAY SPEED™

WELCOME!

Congratulations on your purchase. Use this Owner's Guide to learn about your new vacuum's great features. From assembly to use to maintenance, you will find it all in here.

MAIN UNIT

- A** Hose
- B** Suction Control
- C** Handle Release Latch
- D** Upper Cord Hook
- E** Power/Surface Selector
- F** Lift-Away® Button
- G** Wand
- H** Release Wand Button
- I** Dust-Cup Release Latch
- J** Lower Cord Hook
- K** Motorized Floor Nozzle
- L** Brushroll Indicator Light
- M** Headlights
- N** Brushroll Access Buttons

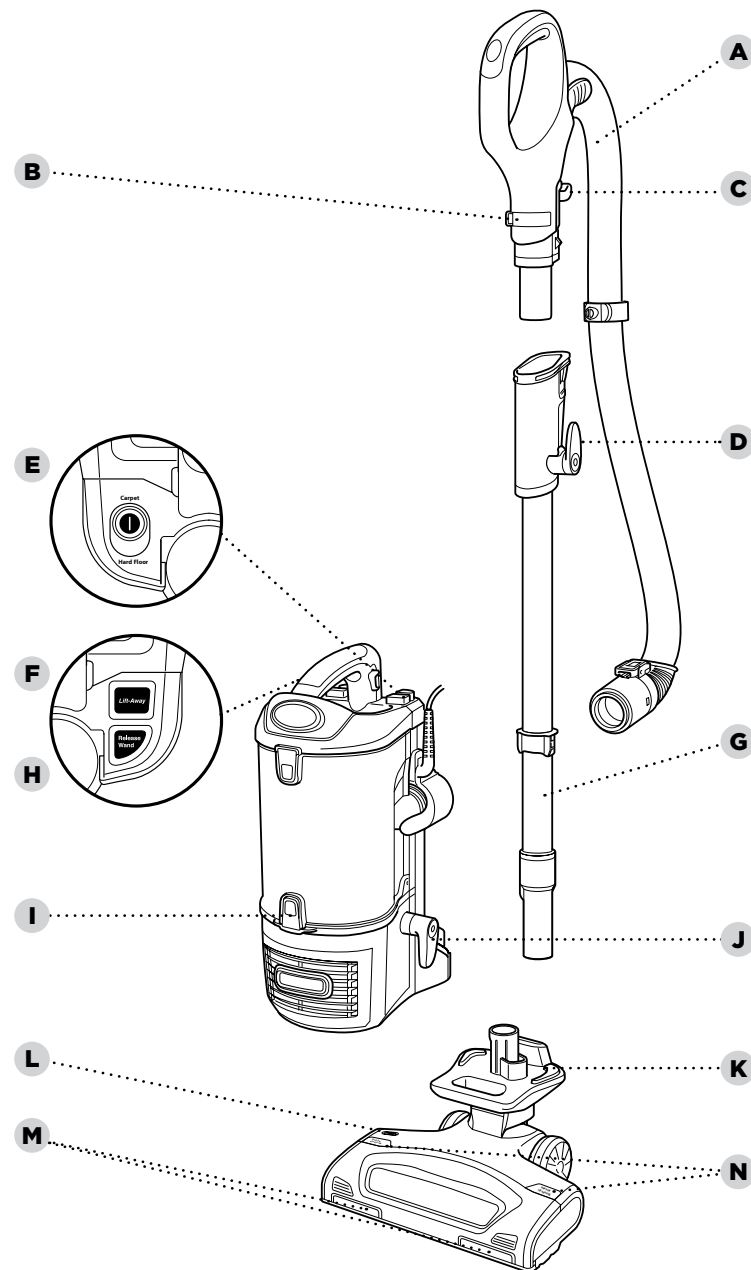

ASSEMBLING YOUR VACUUM

TIP: For quick cord access, rotate upper hook down and remove cord.

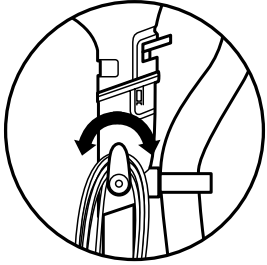

TIP: To store your vacuum, wrap cord around cord hooks.

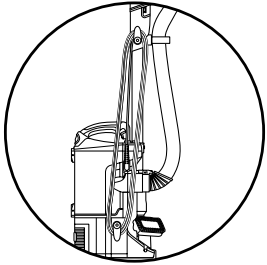

TIP: Use cord clip located on the side of wand to hold cord in place while vacuuming.

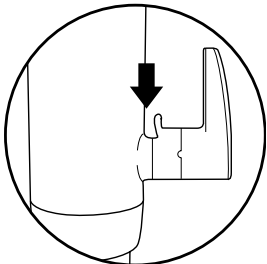

STEP 1

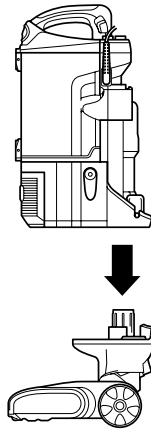

1 Place the pod onto floor nozzle.

STEP 2

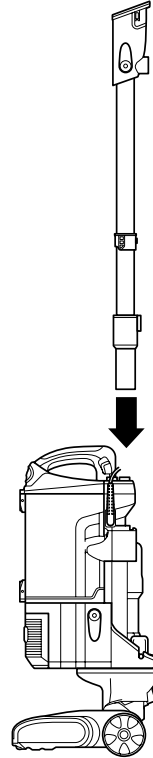

2 Slide wand into base of pod.

STEP 3

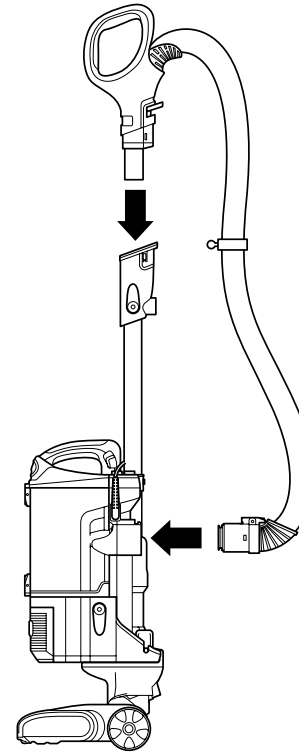

3 Insert handle into top of wand. Then attach hose to hose connector on base of pod.

STEP 4

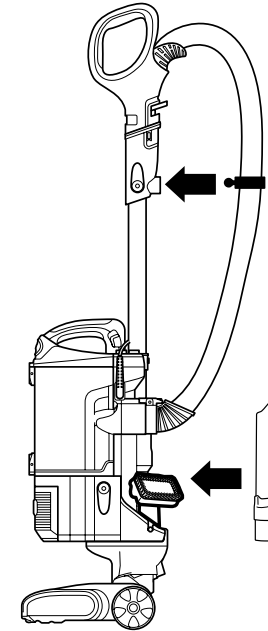

4 Insert tools into accessory holder, then secure the hose to the hose clip by pushing the knob into its socket.

USING YOUR VACUUM IN UPRIGHT MODE

⚠ WARNING: DO NOT use to vacuum up drywall dust, fireplace ash, or embers. DO NOT use as an attachment to power tools for dust collection.

WHAT DOES THE BRUSHROLL INDICATOR LIGHT MEAN?

Solid Green

The brushroll is on and working as it should.

Solid Red

There is a jam in the brushroll area. Turn your vacuum off and remove the blockage.

No Light

The vacuum is off. To turn it on, press the POWER button and put in either carpet or hard floor mode.

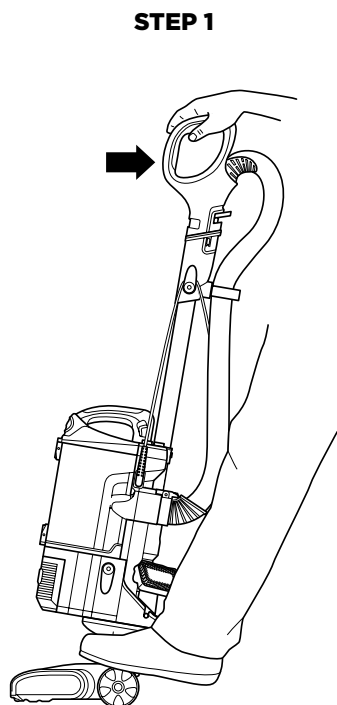

- 1** Plug power cord into outlet. Place foot on floor nozzle and tilt handle back.

STEP 1

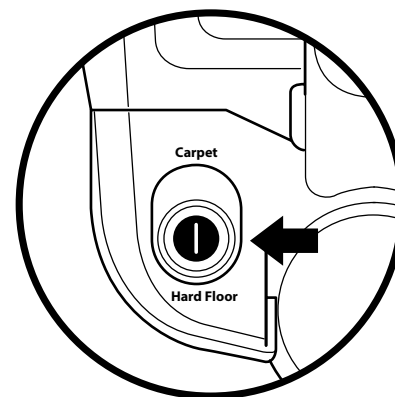

- 2** Slide the power button to Hard Floor setting, then press down to clean hard floor surfaces, area rugs, or above floor. The brushroll will not spin in this mode.

STEP 2

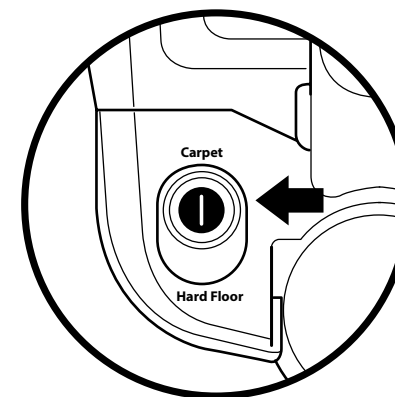

- 3** Slide the power button to Carpet setting and press down to clean carpets. The brushroll will spin fast in this mode for a deep carpet clean.

STEP 3

NOTE: For deep cleaning per ASTM F 608 (embedded dirt in carpets) please ensure power button is set to carpet mode on with the suction control closed.

USING YOUR VACUUM IN ABOVE-FLOOR MODE

THE BENEFITS OF SUCTION CONTROL

Suction Control is a way for you to adjust suction power when you are using different tools or vacuuming different surfaces. For example, if you are feeling resistance while vacuuming thick carpet or upholstery, opening the suction control to MIN will help reduce your push/pull effort.

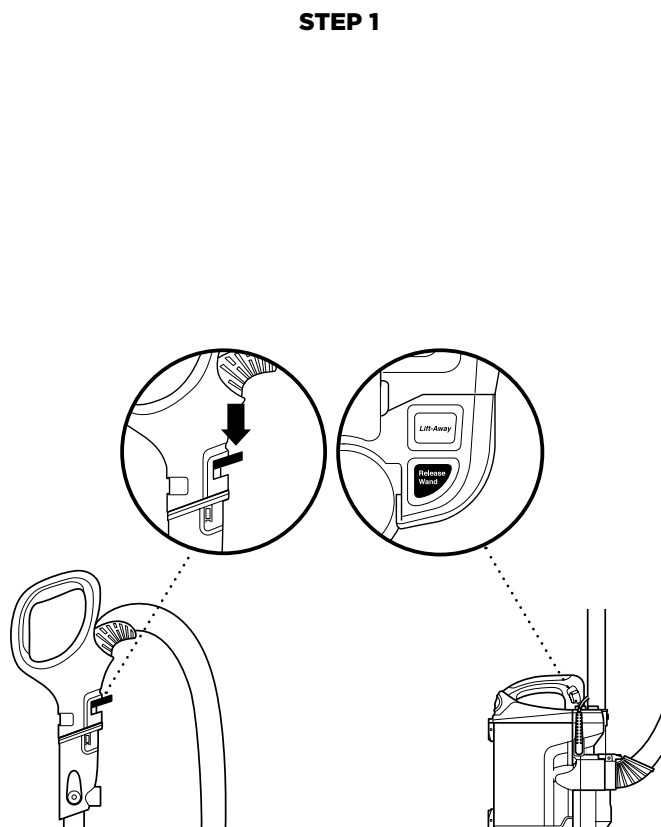

1 To clean within short reach, push handle latch down, then lift the handle up off of the wand.

OR Press Release Wand button on pod when you need to clean with a longer reach.

STEP 1

STEP 2

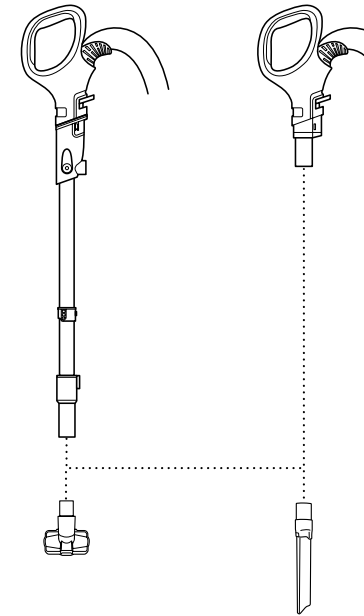

2 Attach desired accessory to the wand or handle.

STEP 3

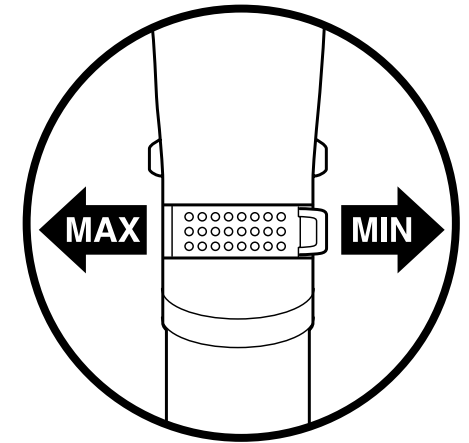

3 Located at the base of the top handle, Suction Control offers variable suction based on your needs. Slide toward MIN to decrease suction, and slide toward MAX to increase suction.

USING YOUR VACUUM IN LIFT-AWAY® MODE

⚠ WARNING: Lift-Away mode requires stable footing. Using Lift-Away mode without stable footing may result in personal injury.

💡 TIP: Hold pod in hand when cleaning in Lift-Away mode.

WHAT IS LIFT-AWAY?

Our Lift-Away feature allows you to remove the pod from the floor nozzle to easily clean stairs, above-floor areas with accessories, or hard floors with the hard-floor attachments.

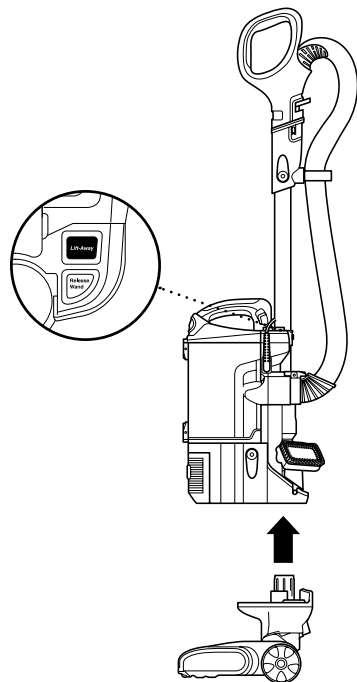

LIFT-AWAY CLEANING

1 Press LIFT-AWAY to lift pod off floor nozzle.

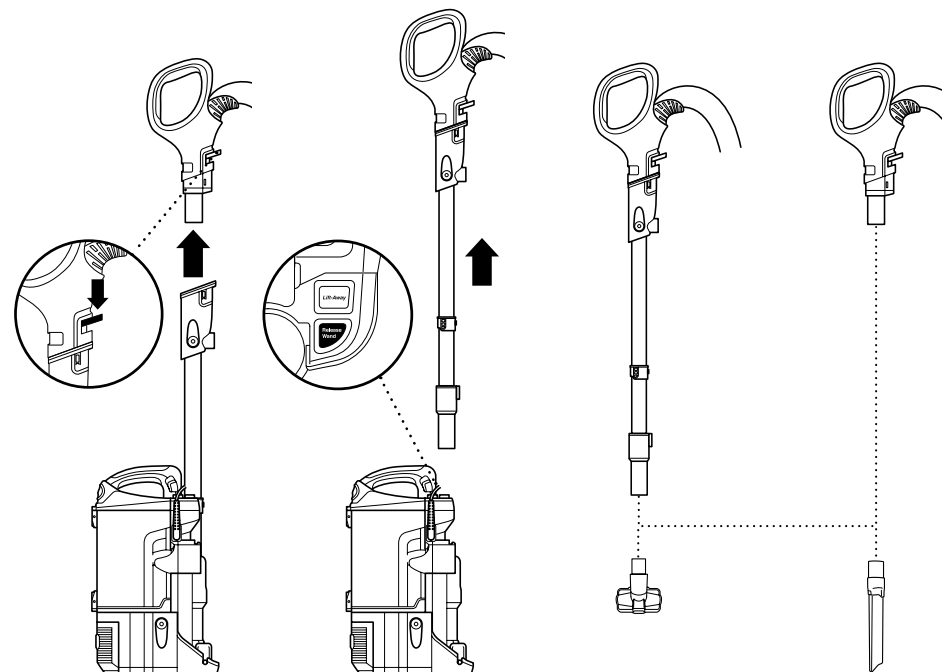

2 To remove the wand from the pod, press the Release Wand button. To release the handle only, push the handle latch down and lift handle up.

3 Attach desired cleaning tool to the end of handle or wand.

COMPATIBLE ACCESSORIES

There are a variety of accessories that are compatible with this vacuum series.

To purchase additional accessories and spare parts, please call:

**AUS 1800 099 385
NZ 0800 112 660**

A Pet Multi Tool (included)

Two cleaning tools in one—the stiff bristle brush gets stuck-on debris off a multitude of surfaces. Remove the bristles to reveal an upholstery tool for removing stubborn pet hair from upholstery and more.

B Hard Floor Hero™

Provides outstanding hard floor cleaning for not just surface litter, but also stuck-on dust and debris. It is small enough to get into hard-to-reach areas and can conveniently be stored on board.

C Crevice Tool (included)

Gives you extended cleaning reach for small spaces.

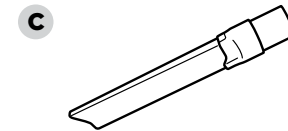
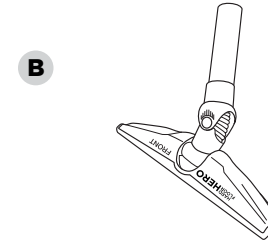
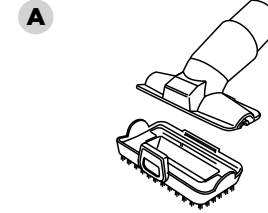

MAINTENANCE

To keep your vacuum's suction power optimal, follow these instructions. Make sure unit is off and cord is unplugged.

⚠ WARNING: To reduce the risk of shock and unintended operation, turn power off and unplug unit before servicing.

Hand wash with water only to prevent damage from cleaning chemicals. Allow ALL filters to dry completely before replacing in the vacuum to prevent liquid from being drawn into electric parts.

★ IMPORTANT: Do not use soap when cleaning the HEPA filter.

RECOMMENDED FILTER CLEANING SCHEDULE:

Pre-Motor Filter Kit
(Foam & Felt)
XFF600
Clean every 3 months.

Post-Motor Filter
(HEPA)
XHF600
Clean once a year.

STEP 1

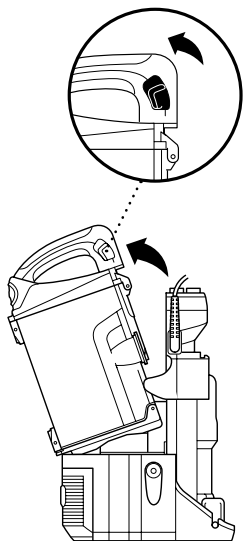

STEP 2

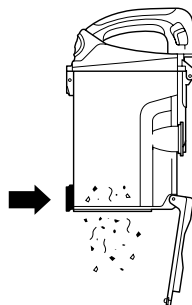

EMPTYING THE DUST CUP

- 1 Lift the dust cup off the pod by pulling up on the release latches on the sides of the dust cup handle.
- 2 Hold dust cup over a trash bin and press the bottom dust-cup release latch.

STEP 3

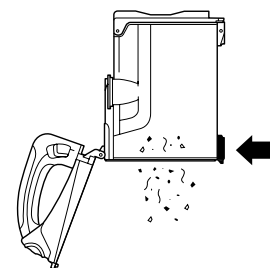

CLEANING THE FILTERS

- 1 **Pre-Motor (foam and felt):** With the dust cup removed, take out the foam and felt filters, and rinse with water. Tap loose dirt off filters between washes as needed.
- 2 **Post-Motor (HEPA):** To access the HEPA filter, reach under the grill, pull the latch forward, and pull the grill away from the vacuum. Remove and rinse the HEPA filter.

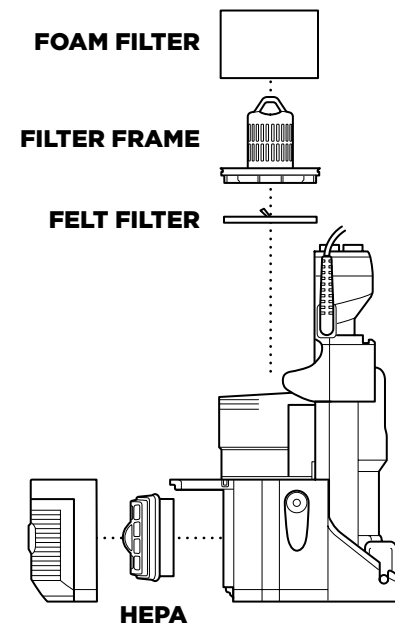

MAINTENANCE

⚠ WARNING: To reduce the risk of shock and unintended operation, turn power off and unplug unit before servicing.

NOTE: Remove dust cup, wand, and floor nozzle and check all dust-cup intake openings.

NOTE: Remove the handle from the extension wand and check for blockages.

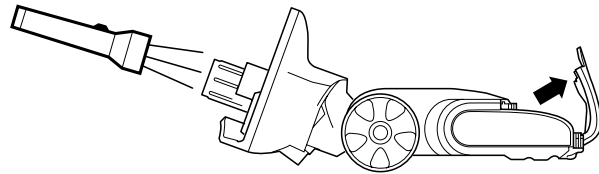

CHECKING FOR BLOCKAGES FLOOR NOZZLE

- 1 Tilt neck of floor nozzle back to straighten the airway and open the Brushroll Garage door. To clear a blockage, insert a long object such as a wooden spoon into the nozzle connector.

STEP 1

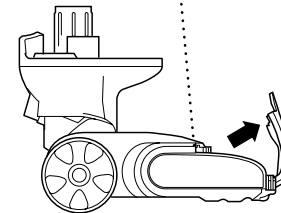
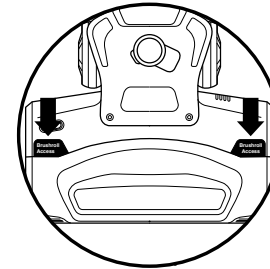

STEP 2

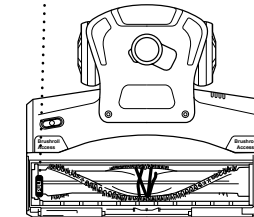
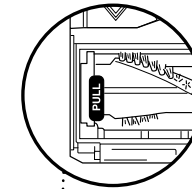

STEP 3

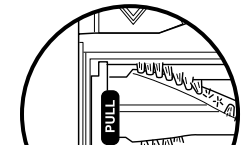

CLEANING THE BRUSHROLL

- 1 Press Brushroll Access buttons to pop up the garage door.
- 2 Lift the brushroll out by the tab on the left side.
- 3 Remove any string, hair or debris that may be wrapped around the brushroll.

TROUBLESHOOTING GUIDE

⚠ WARNING: To reduce the risk of shock and unintended operation, turn power off and unplug unit before servicing.

Vacuum is not picking up debris. No suction or light suction.

(Refer to Maintenance section for more information.)

- Check filters to see if they need cleaning. Follow instructions for rinsing and drying the filters before re-inserting in the vacuum.
- Dust cup may be full; empty dust cup.
- Check hose, hose connections, nozzle, and accessories for blockages; clear blockages if required.
- Remove any string, carpet fibers, or hair that may be wrapped around the brushroll.

Vacuum lifts area rugs.

- Turn off unit to disengage the brushroll. Slide the Power/Surface Selector to the Hard Floor setting to clean with the brushroll off.
- Suction is powerful. Take care when vacuuming area rugs or rugs with delicately sewn edges.
- To minimize suction, refer to Suction Control section for more information.

Brushroll does not spin.

- If Brushroll Indicator Light on the floor nozzle turns red, the brushroll has stopped spinning. Immediately turn off and unplug vacuum and remove blockage before reconnecting and turning vacuum back on.
- With the power on, recline the handle, which will automatically turn on the brushroll.

Brushroll Garage will not close.

- Make sure the brushroll was reinserted correctly with the word "PULL" on the endcap facing up.

Vacuum turns off on its own or Brushroll Indicator Light flashes red.

- This vacuum is equipped with a motor-protective thermostat. If your vacuum overheats, the thermostat will automatically turn the suction motor off. Perform the following steps to restart the thermostat:
 1. Turn vacuum off and unplug it.
 2. Empty dust cup and clean filters (see Maintenance section).
 3. Check for blockages in hose, accessories, and inlet openings.
 4. Allow unit to cool for a minimum of 45 minutes.
 5. Plug in vacuum and turn it on.
 6. Restart the unit in either the Hard Floor or Carpet setting.

Note: If vacuum still does not start, contact Customer Service at AUS 1800 099 385
NZ 0800 112 660

Shark NINJA Two (2) YEAR LIMITED REPLACEMENT WARRANTY

If your product becomes defective due to faulty material or workmanship within a period of 2 years from the date of purchase, we warrant to do the following:

- For New Zealand Consumers: We will replace the product with a new product, free of charge, or repair the product at our cost, at our discretion.
- For Australian Consumers: Our goods come with guarantees that cannot be excluded under the Australian Consumer Law. You are entitled to a replacement or refund for a major failure and for compensation for any other reasonably foreseeable loss or damage. You are also entitled to have the goods repaired or replaced if the goods fail to be of acceptable quality and the failure does not amount to a major failure.

Your warranty is subject to the following conditions:

- DO NOT operate the appliance with a damaged plug or cord, or if the unit has been dropped, damaged or dropped in water. To avoid the risk of electric shock, do not disassemble or attempt to repair the appliance on your own. If the supply cord is damaged, it must be replaced by a qualified electrician in order to avoid a hazard. Incorrect re-assembly or repair can cause a risk of electric shock or injury to persons when the appliance is used.
- The item has not been misused, abused, neglected, altered, modified or repaired by anyone.
- The item has been subjected to fair wear and tear.
- The item has not been used for trade, professional or hire purposes.
- The item has not sustained damage through foreign objects, substances or accident.

Your warranty does not cover;

- Components that are subject to natural wear and tear caused by normal use in accordance with operating instructions.
- Unauthorised/improper maintenance/handling or overload is excluded from this warranty.
- For guarantee claims, you will need to submit a proof of purchase in the form of a valid receipt that displays date and place of purchase.

This warranty does not replace but is in addition to your statutory rights.

This warranty does not apply to accessories supplied with the item.

This warranty applies only to the original purchaser and may not be transferred.

Replacement items will be covered by the limited warranty for the balance of the warranty period from the date of the original purchase.

Please note:

Only the defective product or parts returned to place of purchase will be replaced under this warranty.

Proudly distributed by
Mann&Noble Pty Ltd
No.1 Southridge Unit Estate
2 Southridge Street
Eastern Creek NSW, Australia, 2766
AUS 1800 099 385
NZ 0800 112 660
www.sharkclean.com.au



E4156



GMA-501823-EA

Mann&Noble

Proudly distributed by:

Mann&Noble Pty Ltd

No.1 Southridge Unit Estate
2 Southridge Street
Eastern Creek NSW, Australia, 2766

AUS 1800 099 385

NZ 0800 112 660

www.sharkclean.com.au

Illustrations may differ from actual product. We are constantly striving to improve our products, therefore the specifications contained herein are subject to change without notice.

Shark is a registered trademarks of SharkNinja Operating LLC.
DuoClean and Lift-Away are trademarks of SharkNinja Operating LLC.

© 2016 SharkNinja Operating LLC
NV600ANZMN_IB_MP_180731
PRINTED IN CHINA