

Shark WANDVAC™ SYSTEM **Cordless Handheld Vacuum**

WS632ANZ Series

OWNER'S GUIDE



IMPORTANT SAFETY INSTRUCTIONS

FOR HOUSEHOLD USE ONLY • PLEASE READ ALL INSTRUCTIONS BEFORE USING THIS VACUUM.

To reduce the risk of shock and unintended operation, turn off power and remove the Li-ion battery before servicing.

NOTE: If you have delicate or wool carpets, particularly loop pile, please try the vacuum on a hidden area first to ensure the spinning brushroll do not damage or unpick carpet fibres.

⚠ WARNING

REDUCE THE RISK OF FIRE, ELECTRIC SHOCK, INJURY, OR PROPERTY DAMAGE:

- 1** This vacuum consists of a motorised nozzle, wand, and handheld vacuum. These components contain electrical connections, electrical wiring, and moving parts that potentially present risk to the user.
 - 2** Before each use, carefully inspect all parts for any damage. If a part is damaged, discontinue use.
 - 3** Use only identical replacement parts.
 - 4** This vacuum contains no serviceable parts.
 - 5** Use only as described in this manual. **DO NOT** use the vacuum for any purpose other than those described in this manual.
 - 6** With the exception of the filters and dust cup, **DO NOT** expose any parts of the vacuum to water or other liquids.
 - 7** **DO NOT** allow the appliance to be used by children. Keep the appliance and its cord out of reach of children. Do not allow to be used as a toy. Close supervision is necessary when used near children.
- GENERAL USE**
- 8** This appliance can be used by persons with reduced physical, sensory or mental capabilities or lack of experience and knowledge if they have been given supervision or instruction concerning use of the appliance in a safe way and understand the hazards involved. Cleaning and user maintenance shall not be done by children.
 - 9** Always turn off the vacuum before connecting or disconnecting any current carrying hoses, motorised nozzles, chargers, batteries, or other electrical or mechanical parts.
 - 10** **DO NOT** handle plug or vacuum with wet hands.
 - 11** **DO NOT** use without dust cup, filters, and brushroll in place.
 - 12** Only use Shark® branded filters and accessories. Damage caused by non-Shark filters and accessories may not be covered by the warranty.
 - 13** **DO NOT** put any objects into nozzle or accessory openings. **DO NOT** use with any opening blocked; keep free of dust, lint, hair, and anything that may reduce airflow.
 - 14** **DO NOT** use if nozzle or accessory airflow is restricted. If the air paths or the motorised floor nozzle become blocked, turn the vacuum off. Remove all obstructions before you turn on the unit again.
 - 15** Keep nozzle and all vacuum openings away from hair, face, fingers, uncovered feet, or loose clothing.
 - 16** **DO NOT** use if vacuum is not working as it should, or has been dropped, damaged, left outdoors, or dropped into water.
 - 17** Use extra care when cleaning on stairs.
 - 18** **DO NOT** leave the vacuum unattended while powered on.

- 19** When powered on, keep the vacuum moving over the carpet surface at all times to avoid damaging the carpet fibres.
 - 20** If you have delicate or wool carpets, particularly loop pile, please try the vacuum on a hidden area first to ensure the spinning brushroll do not damage or unpick carpet fibres.
 - 21** **DO NOT** use to pick up:
 - a)** Liquids
 - b)** Large objects
 - c)** Hard or sharp objects (glass, nails, screws, or coins)
 - d)** Large quantities of dust (including drywall, fireplace ash, or embers). **DO NOT** use as an attachment to power tools for dust collection.
 - e)** Smoking or burning objects (hot coals, cigarette butts, or matches)
 - f)** Flammable or combustible materials (lighter fluid, petrol, or kerosene)
 - g)** Toxic materials (chlorine bleach, ammonia, or drain cleaner)
 - 22** **DO NOT** use in the following areas:
 - a)** Poorly lit areas
 - b)** Wet or damp surfaces
 - c)** Outdoor areas
 - d)** Spaces that are enclosed and may contain explosive or toxic fumes or vapours (lighter fluid, petrol, kerosene, paint, paint thinners, mothproofing substances, or flammable dust)
 - 23** Turn off the vacuum before plugging in or unplugging the charger.
 - 24** Turn off the vacuum before any adjustment, cleaning, maintenance or troubleshooting.
 - 25** During cleaning or routine maintenance, **DO NOT** cut anything other than hair, fibres, or string wrapped around the brushroll.
 - 26** Allow all filters to air-dry completely before replacing in the vacuum to prevent liquid from being drawn into electric parts.
 - 27** **DO NOT** modify or attempt to repair the vacuum or the battery yourself, except as indicated in this manual. **DO NOT** use the battery or vacuum if it has been modified or damaged. Damaged or modified batteries may exhibit unpredictable behavior resulting in fire, explosion or risk of injury.
 - 28** Turn off all controls before unplugging.
 - 29** Always turn off this appliance before connecting or disconnecting motorised nozzle or hand tool.
- BATTERY PACK**
- 30** The battery is the power source for the vacuum. Carefully read and follow all charging instructions.
 - 31** To prevent unintentional starting, ensure the vacuum is powered off before picking up or carrying the vacuum. **DO NOT** carry the appliance with your finger on the power switch.
 - 32** Use only Dongguan DongKun Power Technology Co. LTD charger DK012-133090H-S. Use of an incorrect charger may result in no charging, and/or unsafe conditions. Use only Shark® battery XSBT330EU.
 - 33** Keep the battery away from all metal objects such as paper clips, coins, keys, nails, or screws. Shorting the battery terminals increases the risk of fire or burns.
 - 34** If the battery is damaged, liquid may be ejected from the battery. Avoid contact with this liquid, as it may cause irritation or burns. If contact occurs, flush with water. If liquid comes into contact with eyes, seek medical help.
 - 35** Battery should not be stored at temperatures below 37.4°F (3°C) or above 104°F (40°C) to maintain long-term battery life.
 - 36** **DO NOT** charge battery at temperatures below 40°F (5°C) or above 104°F (40°C).
 - 37** Store the appliance indoors. **DO NOT** use or store it below 37.4°F (3°C). Ensure the appliance is at room temperature before operating.
 - 38** **DO NOT** expose the battery to fire or temperatures above 265°F (130°C) as this may cause an explosion.

SAVE THESE INSTRUCTIONS

ASSEMBLY

1. Insert **Wand** into **Nozzle**.
 2. Insert **Handheld Vacuum** into wand.
- For proper operation, ensure all components are completely connected and clicked into place.

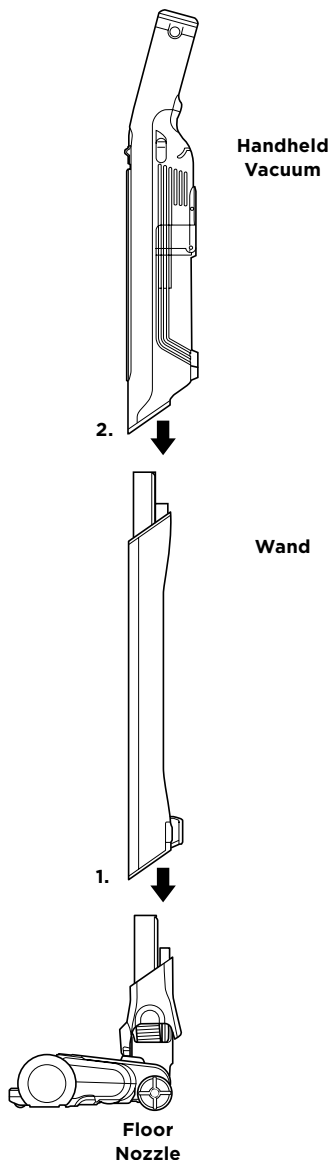

3. Make sure the **Dock Plate** is facing upright. Slide the **Charging Post** into the slot on the back of the dock until it clicks into place.
4. Place the dock on the floor near a power socket. Plug the **Wall Charger** into the socket, then connect the cord to the port on the back of the charging post.
5. Store Duster Crevice on the mount on the dock plate.

NOTE: Once the charging post is installed, it can't be removed.

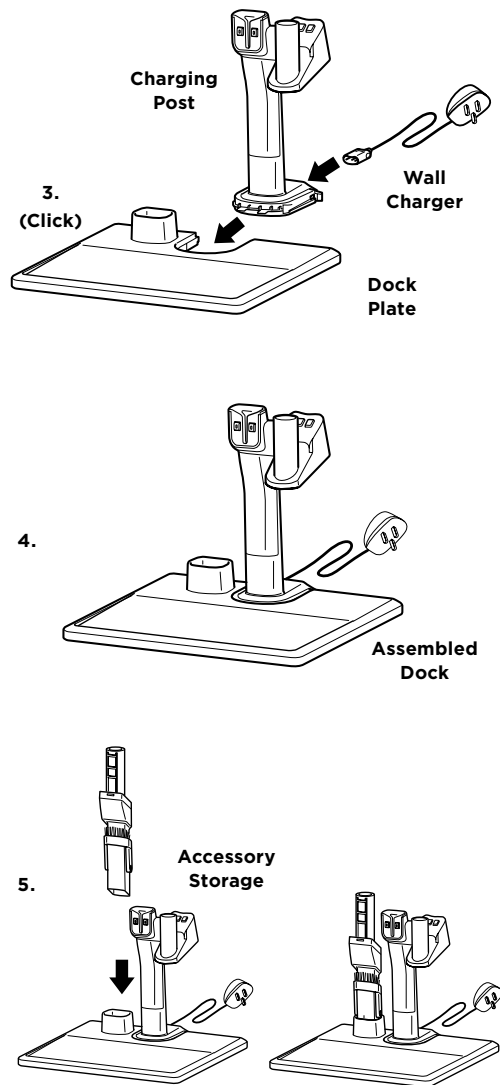

NOTE: Your vacuum's model and serial numbers can be found on the SERIAL # label on the bottom of the back of the handheld vacuum.

LI-ION BATTERY

Prior to first use, charge the battery completely. A full charge takes approximately 3.5 hours.

RUNTIMES PER FULLY CHARGED BATTERY

Visit sharkclean.com.au and sharkclean.co.nz online or review the included Quick Start Guide.

LED BATTERY POWER AND CHARGING INDICATORS

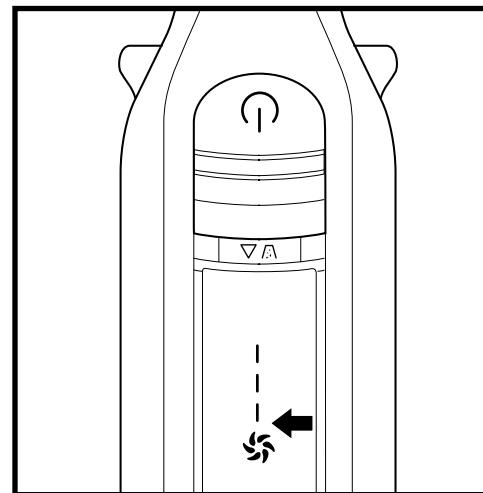

Charging

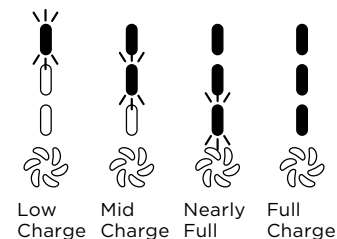

Low Charge Mid Charge Nearly Full Full Charge

NOTE: Full charge takes approximately 3.5 hours. LEDs will shut off 5 minutes after achieving full charge.

In Use

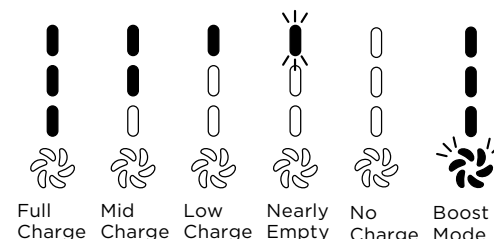

Full Charge Mid Charge Low Charge Nearly Empty No Charge Boost Mode

RECYCLING THE LI-ION BATTERY

This product uses a Li-ion rechargeable and recyclable battery. When the battery no longer holds a charge, it should be removed from the vacuum and recycled. DO NOT incinerate or compost the battery. When your battery needs to be replaced, dispose of it or recycle it in accordance with local regulations. In some areas, it is illegal to place spent lithium-ion batteries in the bin or in a municipal solid waste stream. Return spent batteries to an authorized recycling center for recycling. Contact your local recycling center for information on where to drop off the spent battery.

NOTE: A complete charge takes approximately 3.5 hours. The Li-ion battery will naturally decrease in capacity over time from the 100% capacity of a new battery.

CHARGING AND STORAGE

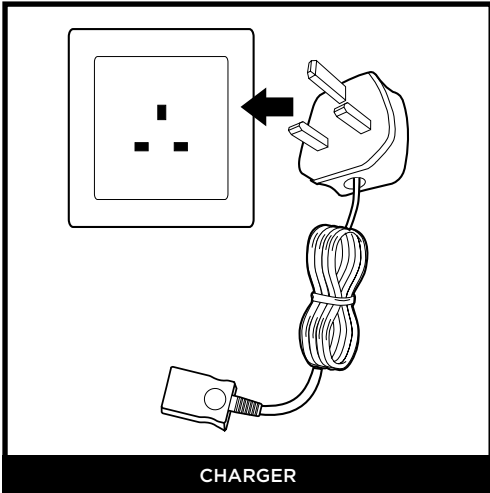

CHARGER

Plug the **Charger** into a wall outlet.

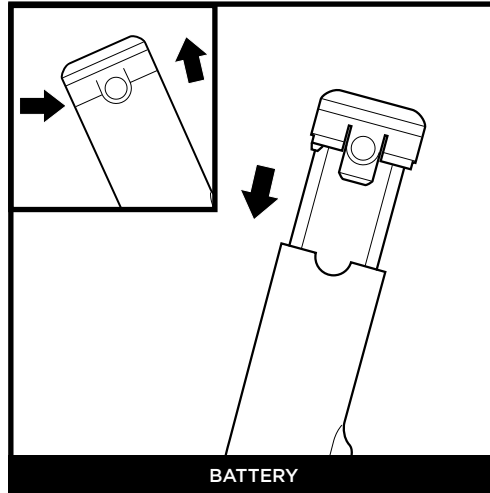

BATTERY

To remove the battery from the hand vac or the charging post, press the release tabs on the battery cap and slide out the battery. To reinstall, slide the battery into the compartment in the handle unit it clicks, or into the slot in the dock charging post.

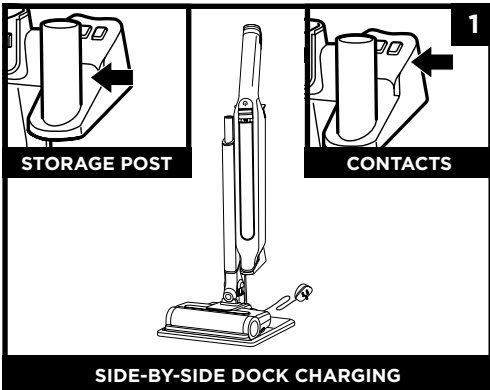

STORAGE POST

CONTACTS

SIDE-BY-SIDE DOCK CHARGING

OPTION 1 - SIDE-BY-SIDE CHARGING DOCK

You can charge the hand vacuum while it is stored beside the wand. First, detach the hand vacuum, then slide the nozzle opening over the storage post. Make sure the contacts on the hand vacuum are aligned with the contacts on the storage arm.

When charging is complete and you need to use the unit again, reattach the hand vacuum and use it to lift the wand and nozzle off the dock plate.

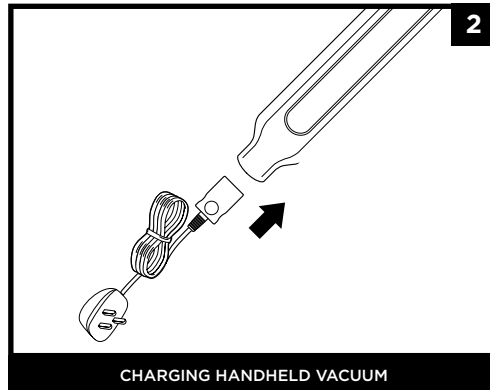

CHARGING HANDHELD VACUUM

OPTION 2 - CHARGING HANDHELD VACUUM

To charge the handheld vacuum alone without the dock, unplug the charger cord from the dock and connect it directly to the port on the handheld vacuum, near the nozzle opening.

NOTE: The main unit comes with a partial charge. For maximum runtime, charge fully before first use (approximately 3.5 hours). Leaving the unit plugged in will not damage battery life..

CONTROLS

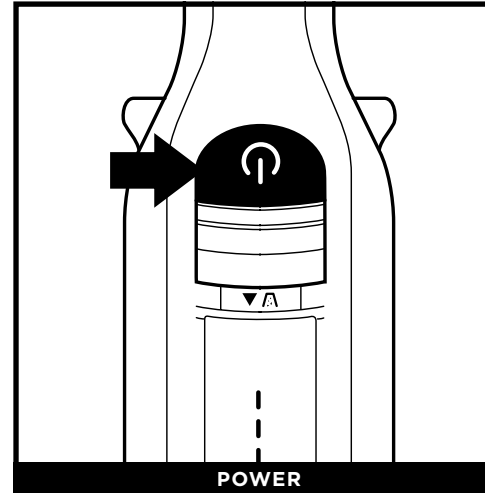

POWER

Press the On/Off button on the handle to turn on power. To turn off power, press the button again.

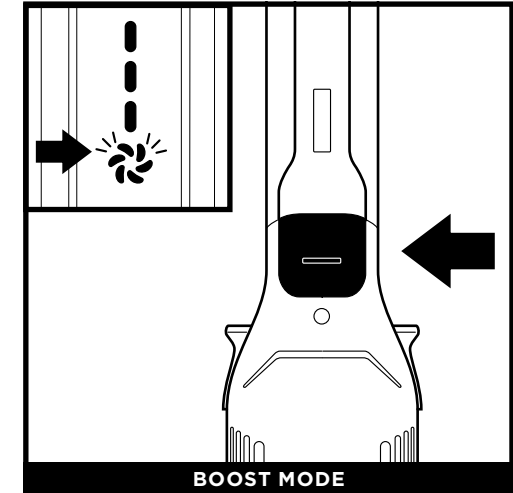

BOOST MODE

For an added boost in power, press and hold the **Button** at the base of the handle of the handheld vacuum. The Boost light will turn white in this mode. Release the button to return to standard power.

CLEANING MODES

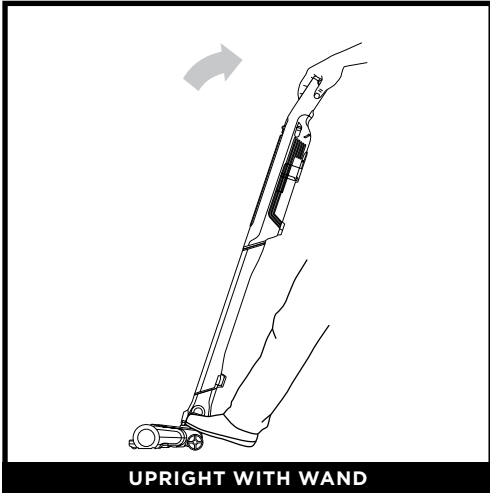

UPRIGHT WITH WAND

To clean floors, place foot on floor nozzle and tilt handheld vacuum back.

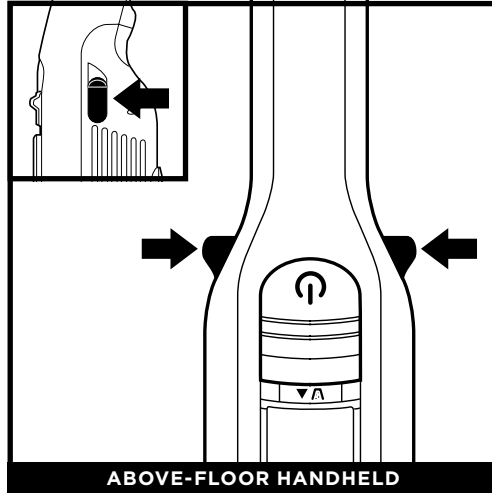

ABOVE-FLOOR HANDHELD

To detach the handheld vacuum from the wand, press the buttons on both sides of the handle, and lift the handheld vacuum off the wand.

To reattach the handheld vacuum to the wand, align the nozzle over the top of the wand and slide it on until it clicks into place.

NOTE: To remove accessories from the hand vac, press the two release tabs on the side of the unit.

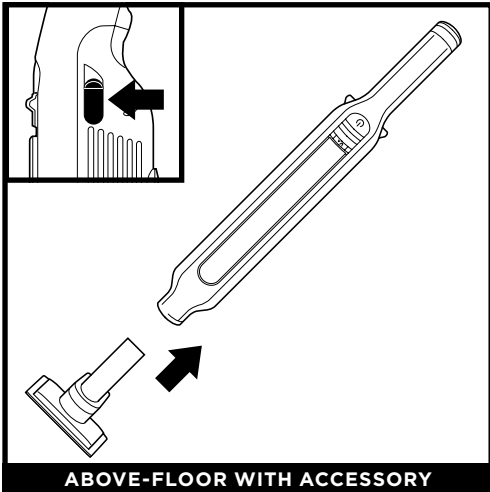

ABOVE-FLOOR WITH ACCESSORY

Attach desired accessory to handheld vacuum. Press buttons on both sides of the handle to remove accessory.

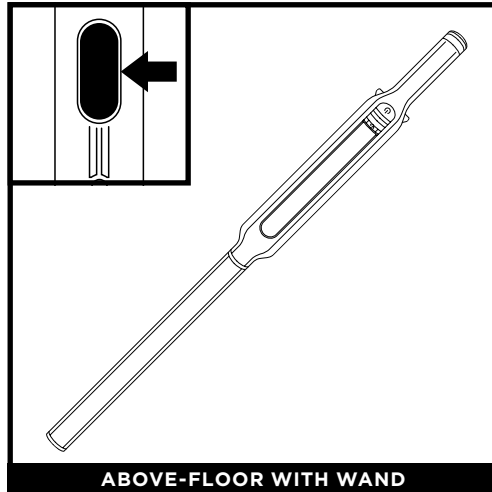

ABOVE-FLOOR WITH WAND

For more reach to clean above-floor areas, detach the floor nozzle from the wand. Step on the floor nozzle, and press the nozzle release button at the bottom of the wand. Lift the wand to remove it.

To reattach the wand, align it over the nozzle neck, then slide it on until it clicks into place.

NOTE: All accessories are compatible with both the wand and the handheld vacuum.

MAINTAINING YOUR VACUUM

EMPTYING THE DUST CUP

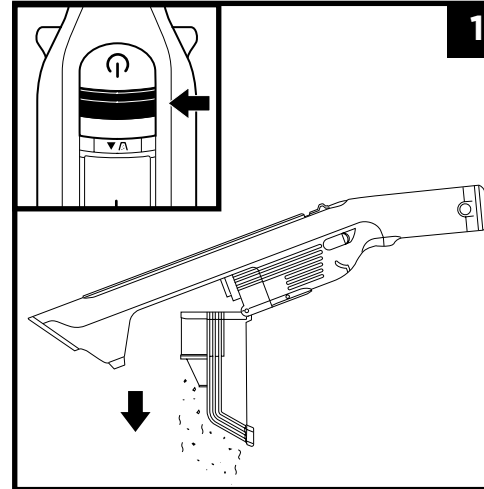

1. With the power off, slide the release button forward, and the dust cup will swing open. Tap the filter screen lightly to knock off dust and debris.

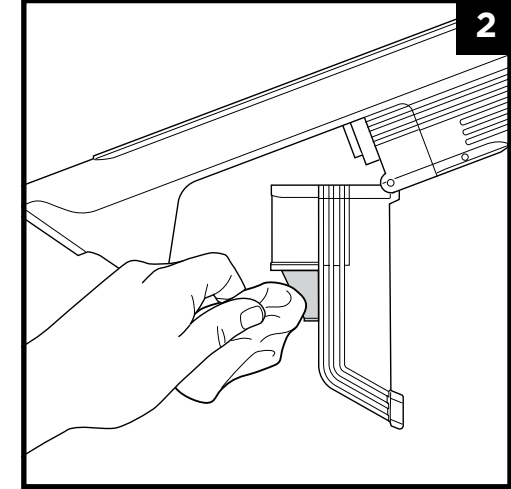

2. Wipe dust screen lightly with cloth to remove dust and dirt.

CLEANING THE DUST CUP AND FILTERS

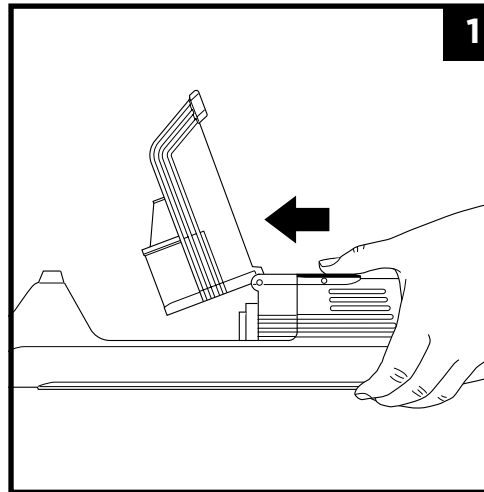

1. With the dust cup open and the power off, press the filter release latch on the bottom of the handle and pull out the filter housing.

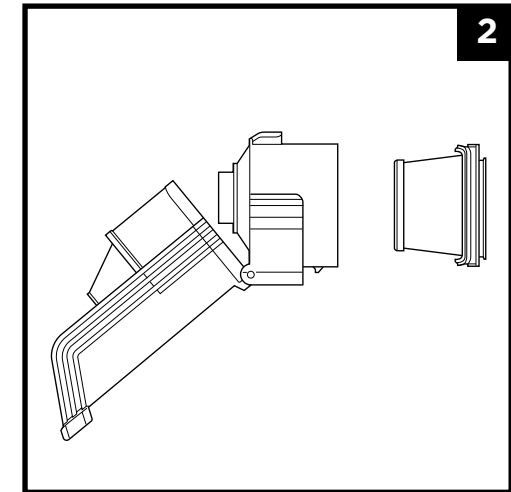

2. Press the tabs on both sides of the filter housing and pull out the filter. To clean the dust cup and filter, rinse them with lukewarm water only. Allow all parts to air-dry completely. To reinstall the filter, slide it back into the housing and press into place.

NOTE: Do not wash any parts or accessories in a dishwasher.

CLEANING THE DUST CUP AND FILTERS

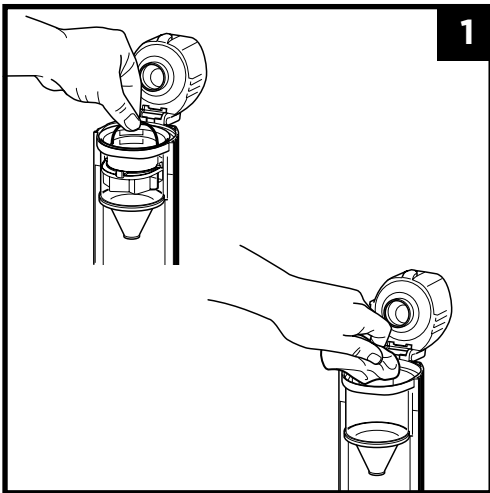

1

1. To deep-clean the dust cup and the cyclone filter, first push the dust cup lid open. Use the wire handle to lift the cyclone filter housing out of the dust cup. Rinse or wipe clean the dust cup and let air-dry for 24 hours.

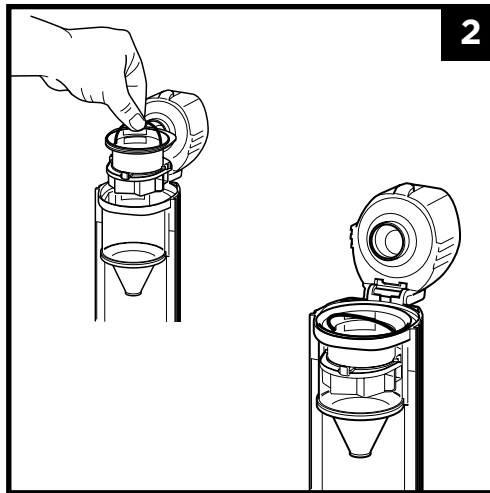

2

2. When the dust cup is completely dry, reinsert the cyclone filter housing. Make sure the wire handle on the filter housing is tucked down. Press the dust cup lid until it is completely shut, then close the dust cup."

CLEANING FLOOR NOZZLE

If you run over a hard or sharp object or notice a noise change while vacuuming, check for blockages or objects caught in the brushroll.

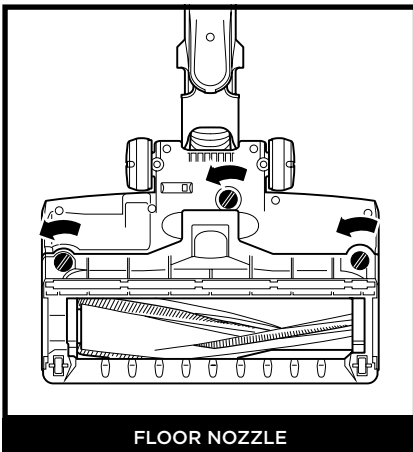

FLOOR NOZZLE

1. Turn off the vacuum.
2. Press the nozzle release button to detach the nozzle from the wand.
3. Using a coin, turn the four locks counterclockwise to open, then lift off the cover and tilt back the neck of the nozzle.
4. Clear any blockages and remove any debris from the brushroll and floor nozzle.
5. Replace the cover by sliding the tabs into the slots. Press down firmly on all sides. Turn locks clockwise to close, until they click into place.

CHECKING FOR BLOCKAGES

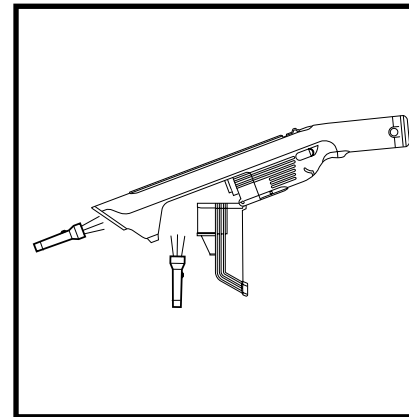

Checking for Blockages in the Handheld Vacuum:

1. Turn off vacuum.
2. Remove the handheld vacuum from the wand.
3. Check all intake openings to the dust cup and remove any debris or blockages.

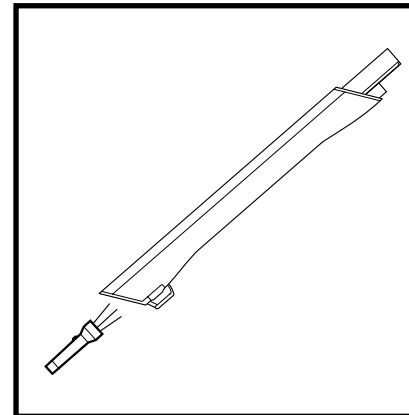

Checking for Blockages in the Wand:

1. Turn off vacuum.
2. Detach the handheld vacuum and floor nozzle from the wand.
3. Check both ends of the wand for blockages and debris.
4. Clear away any debris or blockages.

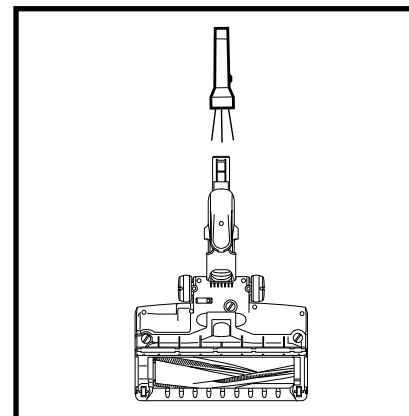

Checking for Blockages in the Floor Nozzle:

1. Turn off vacuum.
2. Detach the wand.
3. Use the edge of a coin to open the four locks on the bottom of the floor nozzle.
4. Remove the cover and tilt back the neck of the floor nozzle.
5. Check the opening and remove any debris or blockages.
6. Replace cover by firmly pressing down on all sides and turning the locks clockwise to close.

MAINTAINING YOUR VACUUM

⚠ WARNING: To reduce the risk of shock and unintended operation, turn off power and remove the battery before servicing.

Vacuum is not picking up debris. No suction or light suction. Third indicator light on hand vacuum is solid yellow.
(Refer to **Checking for Blockages** section for more information.)

- Dust cup may be full; empty dust cup.
- Check floor nozzle for blockages; clear blockages if required.
- Remove any string, carpet fibres, or hair that may be wrapped around the brushroll.
- Check connection between hand vacuum and wand for blockages; clear blockages if required.
- Check filters to see if they need cleaning. Follow instructions for rinsing and completely air-drying the filters before reinstalling them.

Vacuum lifts area rugs.

- Make sure you are not engaging Boost mode. Take care when vacuuming area rugs or rugs with delicately sewn edges.
- Turn off the unit to disengage from the carpet, then restart.

My vacuum's brushroll doesn't spin.

- Immediately turn off the vacuum. Remove any blockages before turning the vacuum back on. Make sure the handheld vacuum is tilted back far enough for the brushroll to engage while in use.

Vacuum turns off on its own.

There are several possible reasons for the vacuum turning off on its own, including blockages, battery issues, and overheating. If vacuum turns off on its own, perform the following steps:

1. Turn on the vacuum and check the battery indicator lights on the hand vacuum. If recharging is needed, make sure vacuum power is off before plugging in the charger.
2. Empty dust cup and clean filters (See the **Cleaning the Dust Cup and Filter** section).
3. Check wand, accessories, and inlet openings and remove any blockages.
4. Allow unit and battery to cool for at least 45 minutes, until they return to room temperature.
5. Press the On/Off switch to restart the vacuum.

Battery Indicator Lights on hand vacuum are flashing.

- Bottom LED is solid yellow (Fig. A): Nozzle clog. (See the **Maintaining Your Vacuum** section.)
- Top LED is flashing (Fig. B): Battery needs to be charged.

Contact Customer Service at AUS 02 8801 7666 or sharkclean.com.au and NZ 0800 112 660 or sharkclean.co.nz if you experience any of the indications listed below:

- Top two LEDs are flashing (Fig. C): Overcurrent or short.
- Top and bottom LEDs are flashing (Fig. D): Motor is overheating.
- Middle LED is flashing (Fig. E): Overspeed.
- Bottom LED is flashing (Fig. F): Communication.
- Bottom LED blinking yellow (Fig. G): There may be an electrical problem with the nozzle.

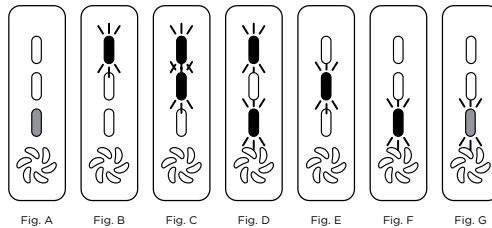

STANDARD ACCESSORIES

- A Battery**
- B Duster Crevice tool**
- C Multi Surface Tool**

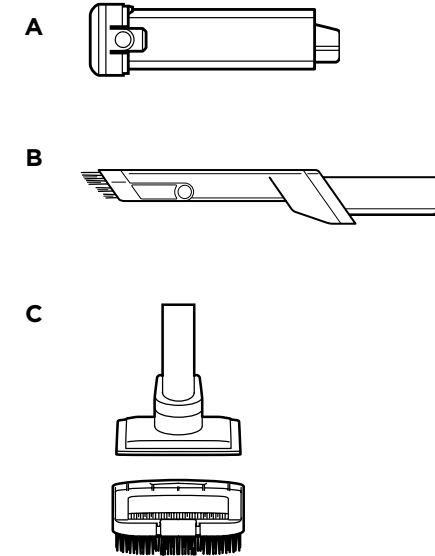

ADDITIONAL ACCESSORIES

- D Motorised Pet Tool (included with some models)**
- E Second Battery (included with some models)**

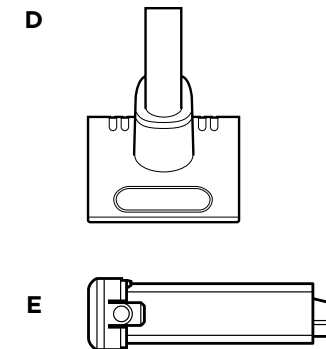

NOTE: If vacuum still does not operate properly, contact Customer Service at **0800 862 0453** or sharkclean.com.au and **NZ 0800 112 660** or sharkclean.co.nz

NOTE: Not all accessories come with all units. Please see the Quick Start Guide for your unit's configuration. To order additional accessories, visit sharkclean.com.au and sharkclean.co.nz

TWO (2) YEAR LIMITED REPLACEMENT WARRANTY

For guarantee claims, you will need to submit a proof of purchase in the form of a valid receipt that displays date and place of purchase. This warranty does not replace but is in addition to your statutory rights.

If your product becomes defective due to faulty material or workmanship within a period of 2 years from the date of purchase, we warrant to do the following:

- For New Zealand Consumers: We will replace the defective/faulty part with a new product, free of charge, or if the unit is deemed defective/faulty we replace the unit with an equivalent or upgraded model, at our discretion.
- For Australian Consumers: Our goods come with guarantees that cannot be excluded under the Australian Consumer Law. You are entitled to a replacement or refund for a major failure and for compensation for any other reasonably foreseeable loss or damage. You are also entitled to have the goods repaired or replaced if the goods fail to be of acceptable quality and the failure does not amount to a major failure.

Replacement items will be covered by the limited warranty for the balance of the warranty period from the date of the original purchase.

Your warranty is subject to the following conditions

- DO NOT operate the appliance with a damaged plug or cord, or if the unit has been dropped, damaged or dropped in water.
- To avoid the risk of electric shock, do not disassemble or attempt to repair the appliance on your own. If the supply cord is damaged, it must be replaced by a qualified electrician to avoid a hazard. Incorrect re-assembly or repair can cause a risk of electric shock or injury to persons when the appliance is used.
- The item has not been misused, abused, neglected, altered, modified or repaired by anyone.
- The item has been subjected to fair wear and tear.
- The item has not been used for trade, professional or hire purposes.
- The item has not sustained damage through foreign objects, substances or accident

Customer costs within warranty

The customer is responsible for any inwards freight charge to return a product for warranty if requested, and outward freight charge for warranty parts and or replacement unit.

Who is covered?

This warranty applies only to the original purchaser, who bought the product from an authorised retailer and may not be transferred. Proof of purchase is required.

What is not covered?

- Filters and brush rolls
- Accessories supplied with the item.
- Components that are subject to natural wear and tear caused by normal use in accordance with operating instructions.
- Unauthorised/improper maintenance/handling or overload is excluded from this warranty.

REGISTER YOUR PURCHASE



AUS sharkclean.com.au
NZ sharkclean.co.nz

RECORD THIS INFORMATION

Model Number: _____

Date Code: _____

Date of Purchase: _____
(Keep receipt)

Store of Purchase: _____

TECHNICAL SPECIFICATIONS

Voltage: 11.1V $\overline{\text{---}}$

Watts: 225W

Benefits of registering your product and creating an account:

- Get easier, faster product support and access to warranty information
- Access troubleshooting and product care instructions
- Be among the first to know about exclusive product promotions

TIP: The model number is on the rating label behind the dust cup.

TIP: The date code is on one of the prongs of the power cord plug.



Mann&Noble

**Proudly distributed by
Mann&Noble Pty Ltd**

Building D, 33 Quarry Road
Erskine Park NSW 2759
Australia

AUS 02 8801 7666
NZ 0800 112 660

Visit us at:
sharkclean.com.au
sharkclean.co.nz

PLEASE READ CAREFULLY AND KEEP FOR FUTURE REFERENCE.

This Owner's Guide is designed to help you get a complete understanding of your new SHARK WANDVAC™ System Cordless Handheld Vacuum.

Illustrations may differ from actual product. We are constantly striving to improve our products; therefore the specifications contained herein are subject to change without notice.

© 2021 SharkNinja Operating LLC. SHARK is a registered trademark of SharkNinja Operating LLC.
SHARK WANDVAC is a trademark of SharkNinja Operating LLC.

WS632ANZSeries_IB_MP_Mv10
PRINTED IN CHINA



@SharkCleanAPAC